

DISASSEMBLY

1. REMOVE PRESSURE PLATE

- (a) Using SST and a socket wrench, remove the shaft bolt.

SST 07112-76060

Torque: 13.2 N·m (135 kgf·cm, 9 ft·lbf)

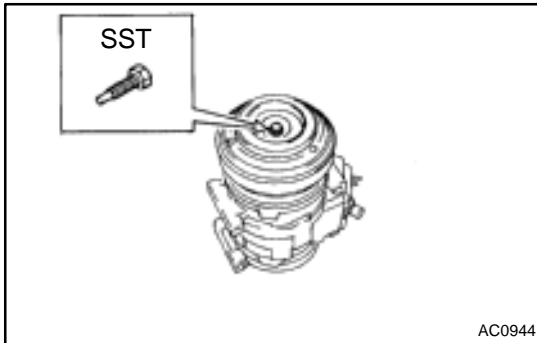

- (b) Install SST on the pressure plate.

SST 07112-66040

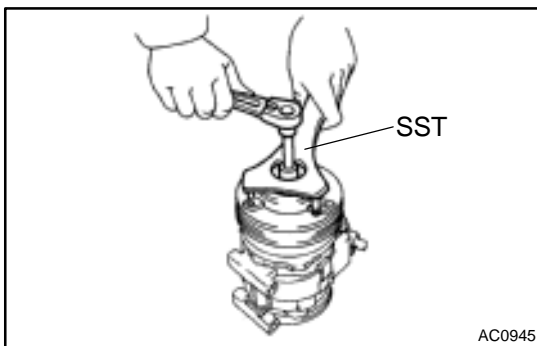

- (c) Using SST and socket wrench, remove the pressure plate.

SST 07112-66040, 07112-76060

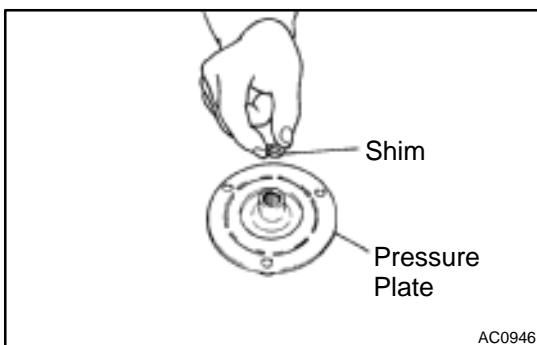

- (d) Remove the shims from the pressure plate.

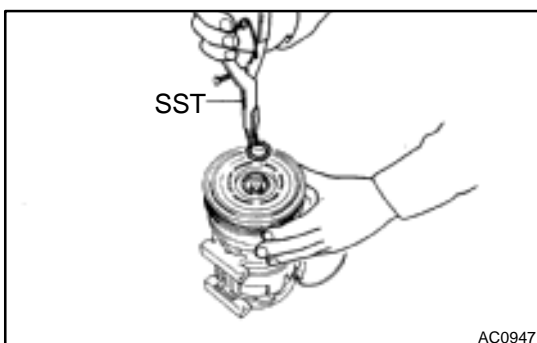

2. REMOVE ROTOR

- (a) Using SST, remove the snap ring.

SST 07114-84020

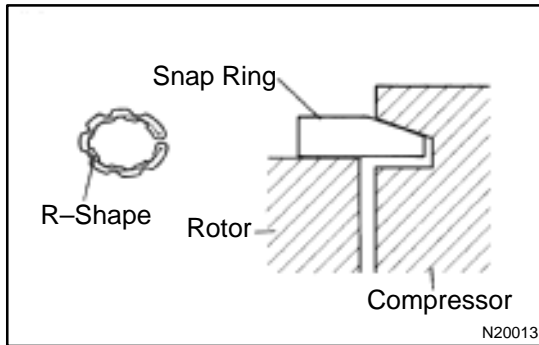
**NOTICE:**

At the time of reassembly, please refer to the following item.

The snap ring should be installed so that beveled side faces up.

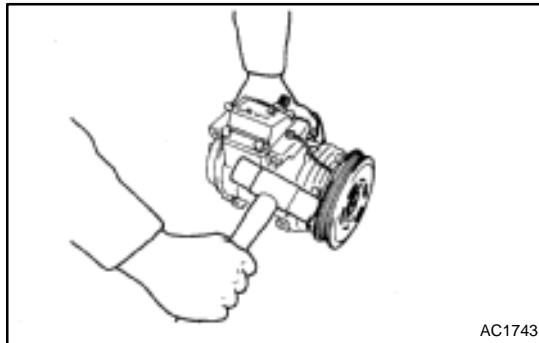

(b) Using a plastic hammer, tap the rotor off the shaft.

NOTICE:

Be careful not to damage the pulley when tapping on the rotor.

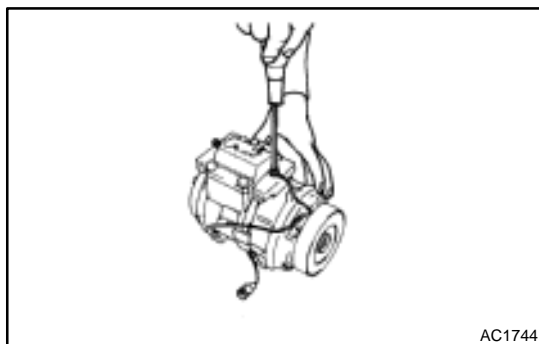
**3. REMOVE STATOR**

(a) Disconnect the stator lead wire from the compressor housing.

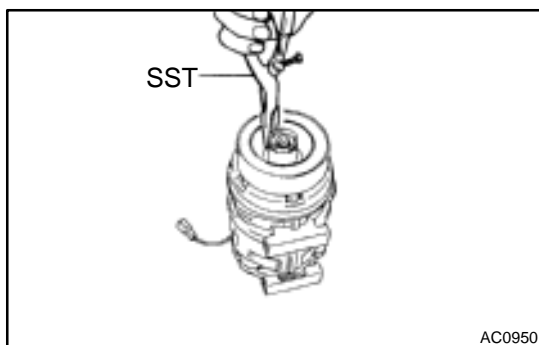

(b) Using SST, remove the snap ring.

SST 07114-84020

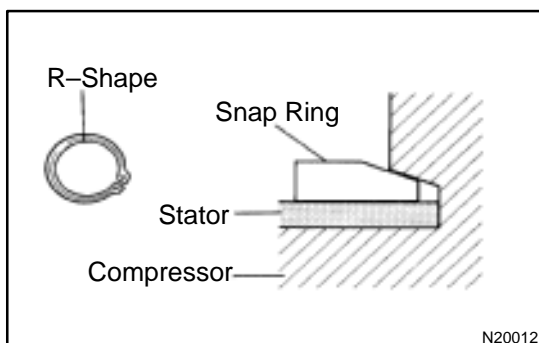
**NOTICE:**

At the time of reassembly, please refer to the following item.

The snap ring should be installed so that its beveled side faces up.

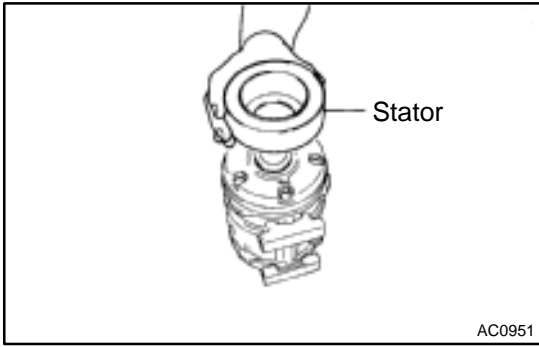

(c) Remove the stator.

AC0951