

COOLING UNIT ON-VEHICLE INSPECTION

AC1FT-01

1. REMOVE LOWER FINISH PANEL
(See page [BO-100](#))

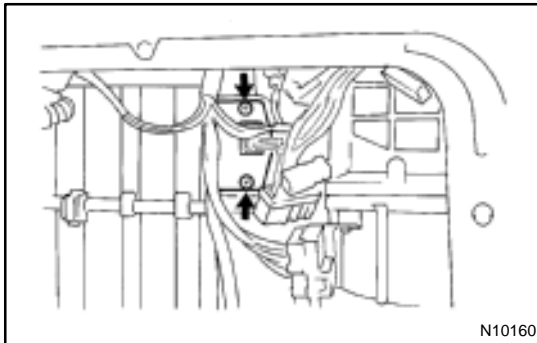

2. REMOVE BLOWER RESISTOR
 - (a) Disconnect the connector.
 - (b) Remove the 2 screws and the blower resistor.
3. INSPECT EVAPORATOR AND FITTINGS FOR LEAKAGE

Using a gas leak detector, check for leakage.
If there is leakage, check the tightening torque at the joints or check the evaporator.

4. CHECK QUANTITY OF GAS DURING REFRIGERATION CYCLE
5. SET ON MANIFOLD GAUGE SET
6. RUN ENGINE
 - (a) Run the engine at 1,500 rpm for at least 5 minutes.
 - (b) Then check that the high pressure reading is 1.37 – 1.57 MPa (14 – 16 kgf-cm², 199 – 228 psi).
7. CHECK EXPANSION VALVE

If the expansion valve is faulty, the low pressure reading will drop to 0 kPa (0 kgf-cm², 0 psi).

HINT:

When the low pressure drops to 0 kPa (0 kgf-cm², 0 psi), feel the receiver's IN and OUT sides for zero temperature difference.

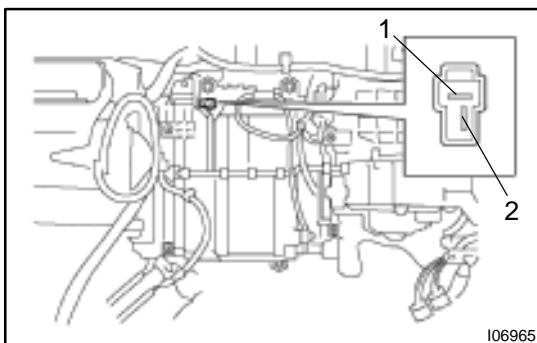

8. INSPECT THERMISTOR RESISTANCE
 - (a) Disconnect the connector.
 - (b) Measure resistance between terminals.
Standard resistance: 1,700 Ω at 25 °C (77 °F)
- If resistance is not as specified, replace the thermistor.