



# Technical Service BULLETIN

March 6, 1998

Title:

## FRONT AXLE HUB NUT REPLACEMENT

Models:

'92 – '98 Tercel, Paseo, Corolla, Celica, Camry  
'96 – '98 RAV4

DRIVE/LINE/DIFFERENTIAL  
DL001-98

**Introduction** Due to a change of the friction control treatment on the nut thread, both types of Front Axle Hub Nuts (silver and black) for 1992 – 1998 Tercel, Paseo, Corolla, Celica, Camry and 1996 – 1998 RAV4s are **NOT reusable**.

**NOTE:**

When replacing the Front Axle Hub Nut the new part must be the same color as the old part. When replacing a Silver nut — use a NEW Silver nut and when replacing a Black nut — use a NEW Black nut.

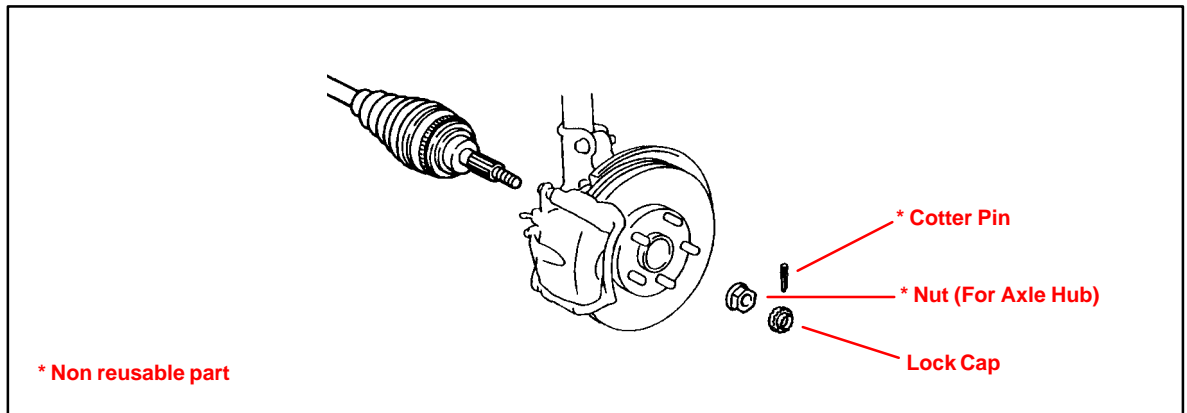

**Affected Vehicles** • 1992 – 1998 Tercel, Paseo, Corolla, Celica, Camry and 1996 – 1998 RAV4s.

**Parts Information**

PART NUMBER	PART NAME	COLOR
90179-22020	Nut, Axle Hub	Silver
90178-22001	Nut, Axle Hub	Black

**Warranty Information**

OP CODE	DESCRIPTION	TIME	OPN	T1	T2
N/A	Not Applicable to Warranty	–	–	–	–

