

# STARTER RELAY

## ON-VEHICLE INSPECTION

1. **REMOVE STARTER RELAY (Marking: ST)**
  - (a) Remove the engine room relay block cover.
  - (b) Remove the starter relay from the engine room relay block.
2. **INSPECT STARTER RELAY**
  - (a) Measure the resistance of the starter relay.

**Standard resistance**

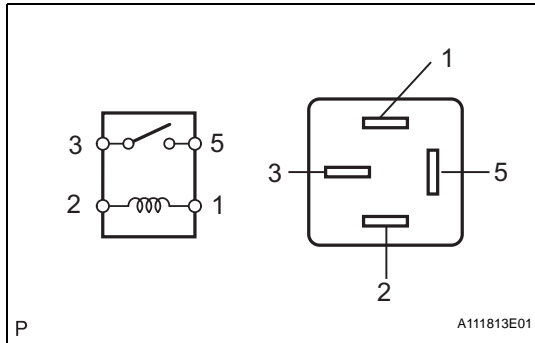

Tester Connection	Specified Condition
3 - 5	10 k $\Omega$ or higher
3 - 5	Below 1 $\Omega$ (when battery voltage is applied to terminals 1 and 2)

If the result is not as specified, replace the relay.

3. **INSTALL STARTER RELAY**