

STARTER COMPONENTS

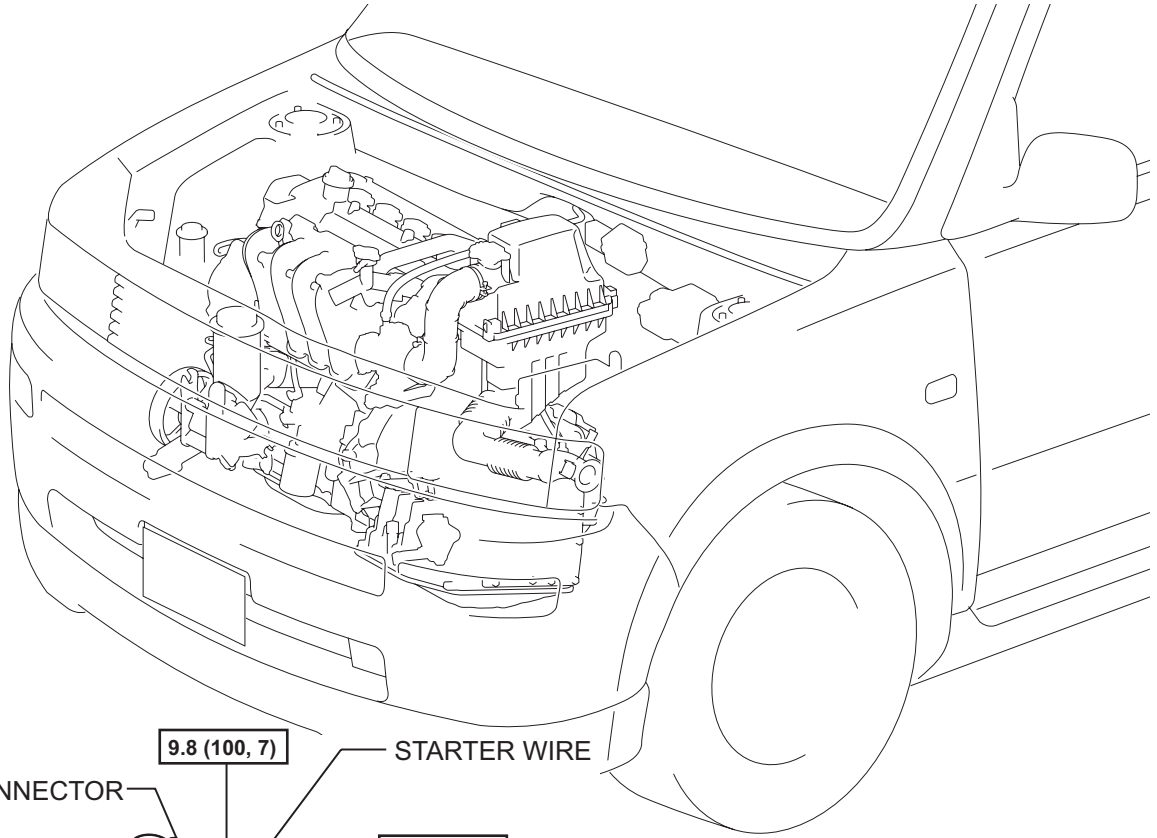

ST

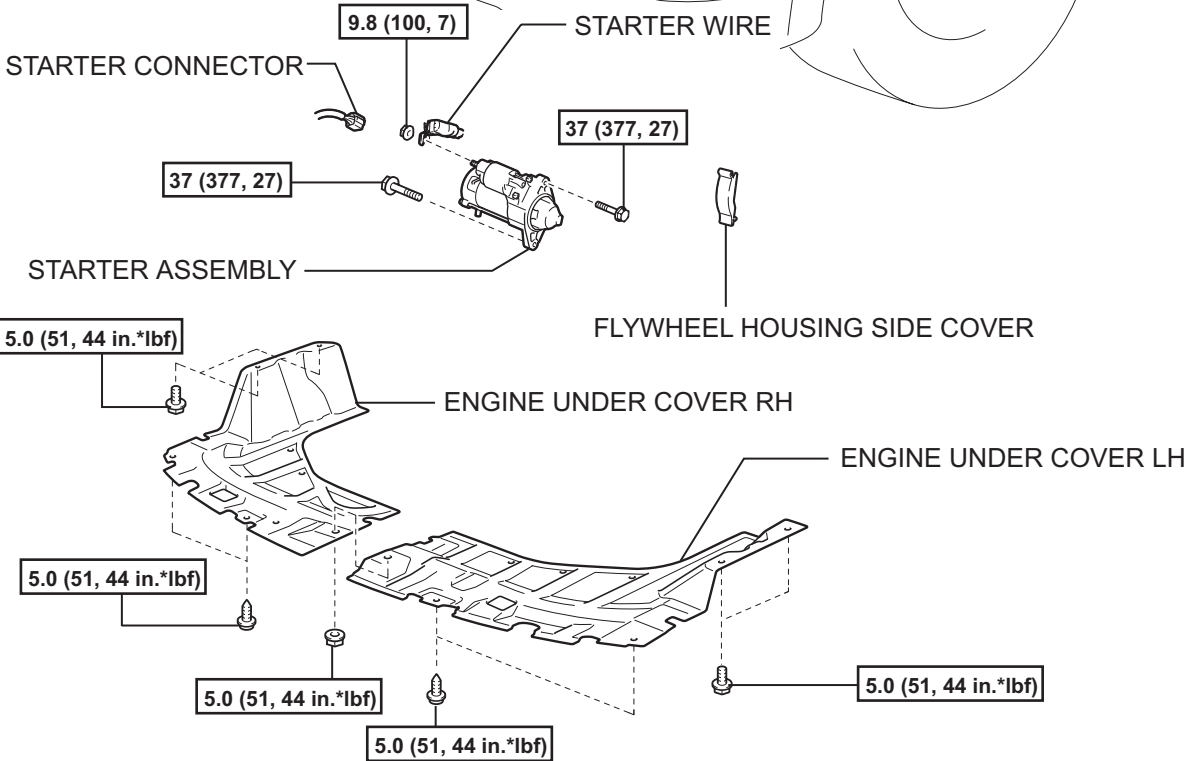

N*m (kgf*cm, ft.*lbf) : Specified torque

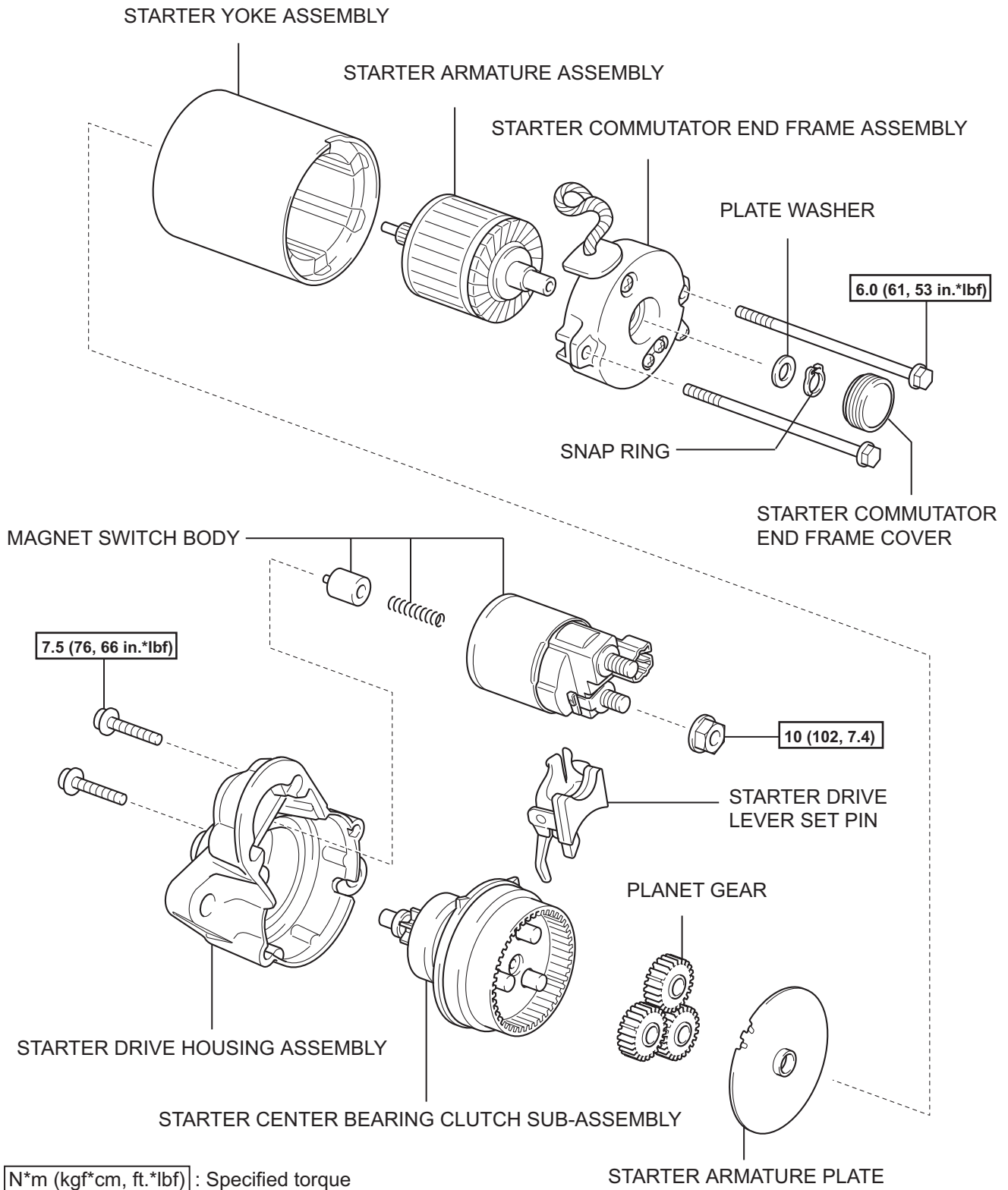

Y

A117209E01