

<b>DTC</b>	<b>P0110</b>	<b>Intake Air Temperature Circuit Malfunction</b>
<b>DTC</b>	<b>P0112</b>	<b>Intake Air Temperature Circuit Low Input</b>
<b>DTC</b>	<b>P0113</b>	<b>Intake Air Temperature Circuit High Input</b>

**DESCRIPTION**

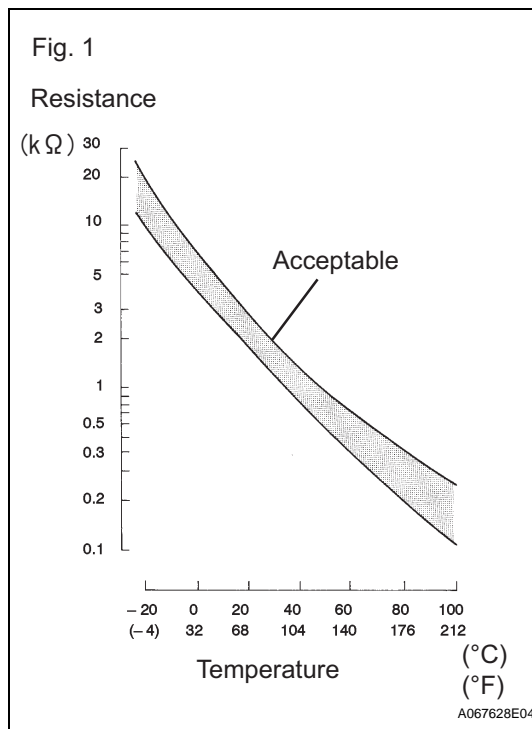

**ES**

The Intake Air Temperature (IAT) sensor, mounted on the Mass Air Flow (MAF) meter, monitors the IAT. The IAT sensor has a built-in thermistor with a resistance that varies according to the temperature of the intake air. When the IAT is low, the resistance of the thermistor increases. When the temperature is high, the resistance drops. These variations in resistance are transmitted to the ECM as voltage changes (see Fig. 1).

The IAT sensor is powered by a 5 V supply from the THA terminal of the ECM, via resistor R. Resistor R and the IAT sensor are connected in series. When the resistance value of the IAT sensor changes according to changes in the IAT, the voltage at terminal THA also varies. Based on this signal, the ECM increases the fuel injection volume when the engine is cold to improve driveability.

**HINT:**

When any of DTCs P0110, P0112 and P0113 are set, the ECM enters fail-safe mode. During fail-safe mode, the IAT is estimated to be 20°C (68°F) by the ECM. Fail-safe mode continues until a pass condition is detected.

DTC No.	DTC Detection Condition	Trouble Area
P0110	Open or short in IAT sensor circuit for 0.5 seconds (1 trip detection logic)	<ul style="list-style-type: none"> <li>Open or short in IAT sensor circuit</li> <li>IAT sensor (built into MAF meter)</li> <li>ECM</li> </ul>
P0112	Short in IAT sensor circuit for 0.5 seconds (1 trip detection logic)	<ul style="list-style-type: none"> <li>Short in IAT sensor circuit</li> <li>IAT sensor (built into MAF meter)</li> <li>ECM</li> </ul>
P0113	Open in IAT sensor circuit for 0.5 seconds (1 trip detection logic)	<ul style="list-style-type: none"> <li>Open in IAT sensor circuit</li> <li>IAT sensor (built into MAF meter)</li> <li>ECM</li> </ul>

**HINT:**

When any of these DTCs are set, check the IAT by entering the following menus on the intelligent tester: DIAGNOSIS / ENHANCED OBD II / DATA LIST / PRIMARY / INTAKE AIR.

Temperature Displayed	Malfunction
-40°C (-40°F)	Open circuit
140°C (284°F) or higher	Short circuit

**MONITOR DESCRIPTION**

The ECM monitors the sensor voltage and uses this value to calculate the Intake Air Temperature (IAT). When the sensor output voltage deviates from the normal operating range, the ECM interprets this as a malfunction in the IAT sensor and sets a DTC.

Example:

If the sensor output voltage is 4.91 V for 0.5 seconds or more, the ECM determines that there is an open in the IAT sensor circuit, and sets DTC P0113. Conversely, if the output voltage is more than 0.18 V for 0.5 seconds or more, the ECM determines that there is a short in the sensor circuit, and sets DTC P0112. If the malfunction is not repaired successfully, a DTC is set 0.5 seconds after the engine is next started.

**MONITOR STRATEGY**

Related DTCs	P0110: Intake air temperature sensor range check (Fluctuating) P0112: Intake air temperature sensor range check (Low resistance) P0113: Intake air temperature sensor range check (High resistance)
Required Sensors/Components (Main)	Intake Air Temperature (IAT) sensor
Required Sensors/Components (Related)	-
Frequency of Operation	Continuous
Duration	0.5 seconds
MIL Operation	Immediate
Sequence of Operation	None

**TYPICAL ENABLING CONDITIONS**

Monitor runs whenever following DTCs not present	None
--	------

**TYPICAL MALFUNCTION THRESHOLDS****P0110:**

IAT sensor voltage	Less than 0.18 V, or more than 4.91 V
--------------------	---------------------------------------

**P0112:**

IAT sensor voltage	Less than 0.18 V
--------------------	------------------

**P0113:**

IAT sensor voltage	More than 4.91 V
--------------------	------------------

**COMPONENT OPERATING RANGE**

IAT sensor voltage	0.18 to 4.91 V
--------------------	----------------

**WIRING DIAGRAM**

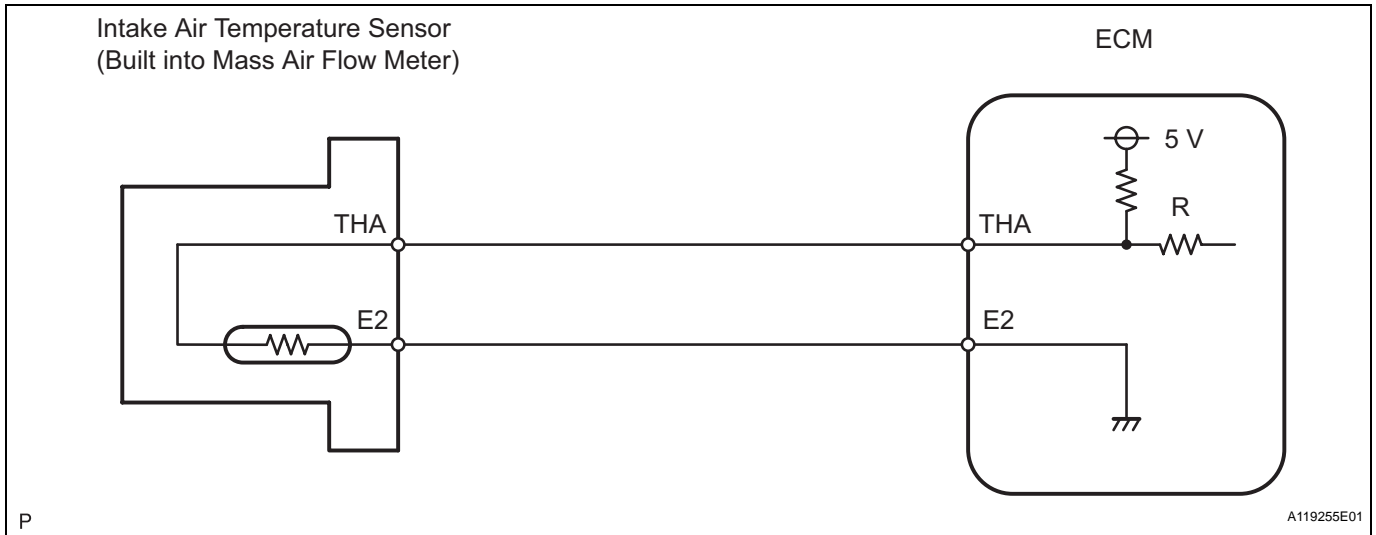

**ES**

**HINT:**

- If other DTCs relating to different systems that have terminal E2 as the ground terminal are output simultaneously, terminal E2 may have an open circuit.
- Read freeze frame data using the intelligent tester. Freeze frame data records the engine condition when malfunctions are detected. When troubleshooting, freeze frame data can help determine if the vehicle was moving or stationary, if the engine was warmed up or not, if the air-fuel ratio was lean or rich, and other data from the time the malfunction occurred.

**1 READ VALUE OF INTELLIGENT TESTER (INTAKE AIR TEMPERATURE)**

- Connect the intelligent tester to the DLC3.
- Turn the ignition switch ON and turn the tester ON.
- Enter the following menus: DIAGNOSIS / ENHANCED OBD II / DATA LIST / PRIMARY / INTAKE AIR.
- Read the value displayed on the tester.

**Standard:**

**Same as actual Intake Air Temperature (IAT).**

**Result**

Temperature Displayed	Proceed to
-40°C (-40°F)	A
140°C (284°F) or higher	B
Same as actual IAT	C

**HINT:**

- If there is an open circuit, the intelligent tester indicates -40°C (-40°F).
- If there is a short circuit, the intelligent tester indicates 140°C (284°F) or higher.

**B** → **Go to step 4**

**C** → **CHECK FOR INTERMITTENT PROBLEMS**

**A**

**2 READ VALUE OF INTELLIGENT TESTER (CHECK FOR OPEN IN WIRE HARNESS)**

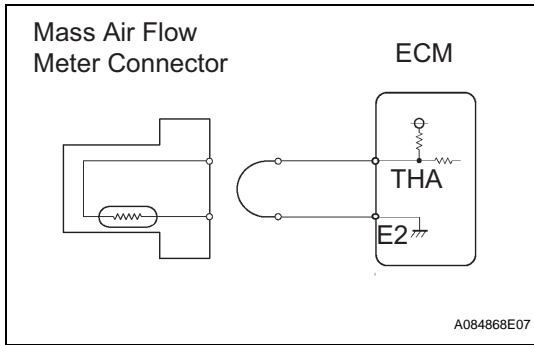

(a) Disconnect the M1 Mass Air Flow (MAF) meter connector.

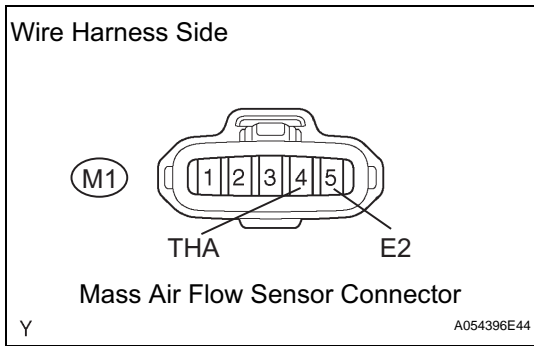

- (b) Connect terminals THA and E2 of the MAF meter wire harness side connector.
- (c) Connect the intelligent tester to the DLC3.
- (d) Turn the ignition switch ON and turn the tester ON.
- (e) Enter the following menus: DIAGNOSIS / ENHANCED OBD II / DATA LIST / PRIMARY / INTAKE AIR.
- (f) Read the value displayed on the tester.

**Standard:**  
**140°C (284°F) or higher**

**OK**

**CONFIRM GOOD CONNECTION TO SENSOR. IF OK, REPLACE MASS AIR FLOW METER**

**NG**

**3 READ VALUE OF INTELLIGENT TESTER (CHECK FOR OPEN IN ECM)**

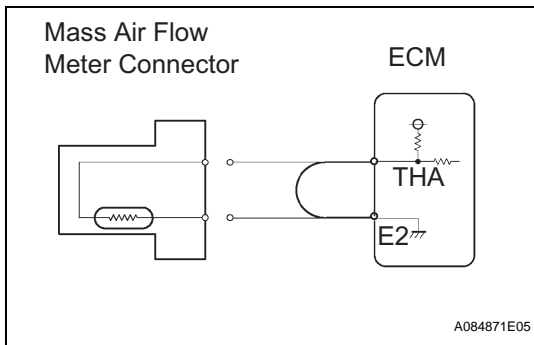

(a) Disconnect the M1 MAF meter connector.

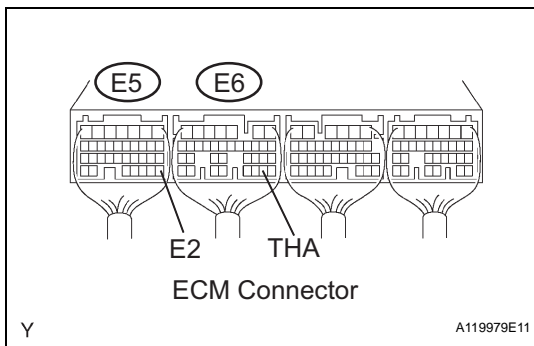

(b) Connect terminals THA and E2 of the E5 and E6 ECM connectors.

**HINT:**

Before checking, perform visual and contact pressure checks on the ECM connector.

- (c) Connect the intelligent tester to the DLC3.
- (d) Turn the ignition switch ON and turn the tester ON.
- (e) Enter the following menus: DIAGNOSIS / ENHANCED OBD II / DATA LIST / PRIMARY / INTAKE AIR.
- (f) Read the value displayed on the tester.

**Standard:**  
**140°C (284°F) or higher**

**OK** REPAIR OR REPLACE HARNESS OR CONNECTOR

**NG**

**CONFIRM GOOD CONNECTION TO ECM. IF OK, REPLACE ECM**

**4 READ VALUE OF INTELLIGENT TESTER (CHECK FOR SHORT IN WIRE HARNESS)**

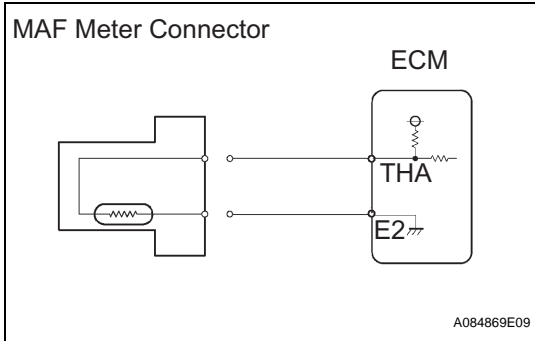

- (a) Disconnect the M1 MAF meter connector.
  - (b) Connect the intelligent tester to the DLC3.
  - (c) Turn the ignition switch ON and turn the tester ON.
  - (d) Enter the following menus: DIAGNOSIS / ENHANCED OBD II / DATA LIST / PRIMARY / INTAKE AIR.
  - (e) Read the value displayed on the tester.
- Standard:**  
-40°C (-40°F)

**ES**

**OK** REPLACE MASS AIR FLOW METER

**NG**

**5 READ VALUE OF INTELLIGENT TESTER (CHECK FOR SHORT IN ECM)**

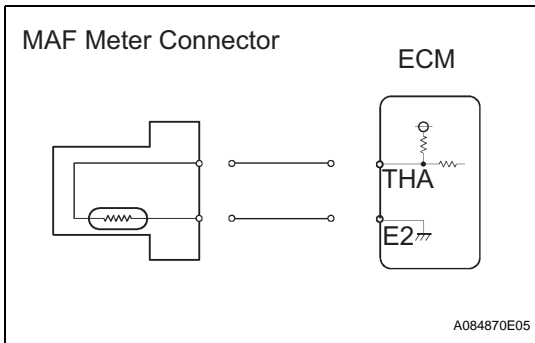

- (a) Disconnect the E5 and E6 ECM connectors.

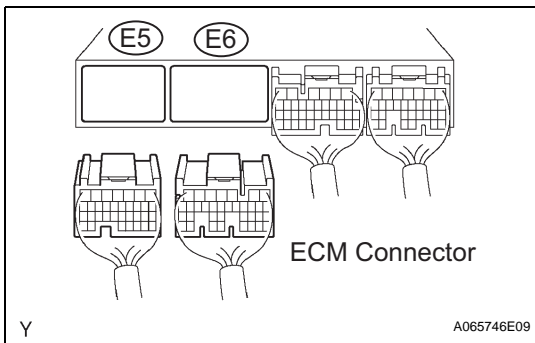

- (b) Connect the intelligent tester to the DLC3.
  - (c) Turn the ignition switch ON and turn the tester ON.
  - (d) Enter the following menus: DIAGNOSIS / ENHANCED OBD II / DATA LIST / PRIMARY / INTAKE AIR.
  - (e) Read the value displayed on the tester.
- Standard:**  
-40°C (-40°F)

**OK** REPAIR OR REPLACE HARNESS OR CONNECTOR

**NG**

**REPLACE ECM**