

Part Number: PTS20-52040

NOTE: Part number of this accessory may not be the same as the part number shown.

Kit Contents

Item #	Quantity Req'd.	Description
1	1	Bazooka Tube Assembly
2	1	Wire Harness
3	1	Hardware Bag
4	4	Paper Drill Templates
5	1	Installation Instructions
6	1	Care Card

Hardware Bag Contents

Item #	Quantity Req'd.	Description
1	10	7" Wire Ties
2	10	4" Wire Ties
3	4	M6 X 30mm Bolts
4	2	M6 X 25mm Bolts
5	2	Threaded Backing Plates
6	2	Top Mounting Plates
7	2	Bracket Mounting Knobs

Additional Items Required For Installation

Item #	Quantity Req'd.	Description
1		

Conflicts

None

Recommended Tools

Personal & Vehicle Protection	Notes
Vehicle Protection	Seat/Floor Covers
Part Protection	Blankets
Special Tools	Notes
Arch Punch (For use with Rear Cargo Mat only)	5/16" Hole Diameter (McMaster PN: 3427A12)
Mallet (For use with Rear Cargo Mat only)	Rubber Mallet
Marker	
Installation Tools	Notes
Panel Removal Tool	Nylon Removal Tool (NRT)
Socket/Ratchet	10mm & 12mm
Socket Extension	6 inch (optional)
Torque Wrench	3 lbf-ft , and 10 lbf-ft
Pliers	1. Diagonal Cutters 2. Long Nose (optional)
Screwdriver	Magnetized Philips # 2
Electric Drill	5/16" Drill Bit
Utility Knife	
Special Chemicals	Notes
Cleaner	3M™ Prep Solvent-70 (if required)

General Applicability

All SCION xB Grades

Recommended Sequence of Application

Item #	Accessory
1	Install Security/Audio
2	Install Bazooka Tube
3	Install Door Sills
4	Install Molded Dash

*Mandatory

Vehicle Service Parts (may be required for reassembly)

Item #	Quantity Req'd.	Description
1		

Legend

 **STOP:** Damage to the vehicle may occur. Do not proceed until process has been complied with.

 **OPERATOR SAFETY:** Use caution to avoid risk of injury.

 **CAUTION:** A process that must be carefully observed in order to reduce the risk of damage to the accessory/vehicle and to ensure a quality installation.

 **TOOLS & EQUIPMENT:** Used in Figures calls out the specific tools and equipment recommended for this process.

 **REVISION MARK:** This mark highlights a change in installation with respect to previous issue.

Bass Tube Specifications

Woofers Size	8"
Voice Coil Size	1"high power/high temp.
Magnet Size	15 oz.
Frequency Response	39 – 85 hz.
Efficiency	105dB
Power Handling	100 watts
Dimensions	18.125" x 8.5" x 10"
Weight	14 lbs.
Impedance	2 ohms DVC

Care must be taken when installing this accessory to ensure damage does not occur to the vehicle. The installation of this accessory should follow approved guidelines to ensure a quality installation.

These guidelines can be found in the "Accessory Installation Practices" document.

This document covers such items as:-

- Vehicle Protection (use of covers and blankets, cleaning chemicals, etc.).
- Safety (eye protection, rechecking torque procedure, etc.).
- Vehicle Disassembly/Reassembly (panel removal, part storage, etc.).
- Electrical Component Disassembly/Reassembly (battery disconnection, connector removal, etc.).

Please see your Toyota dealer for a copy of this document.

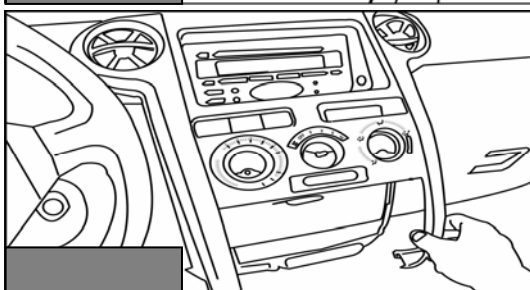
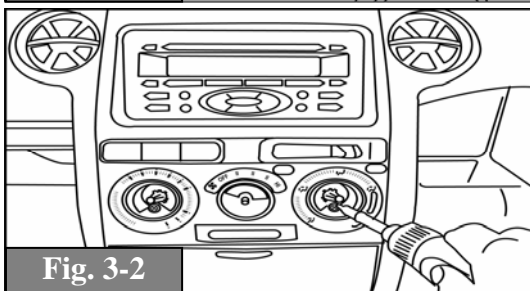
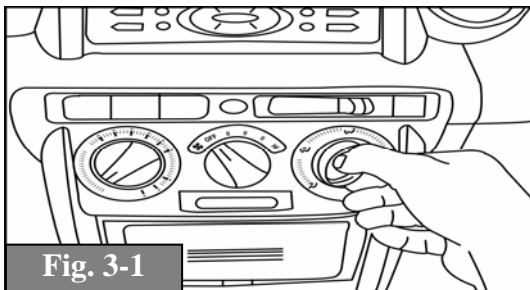
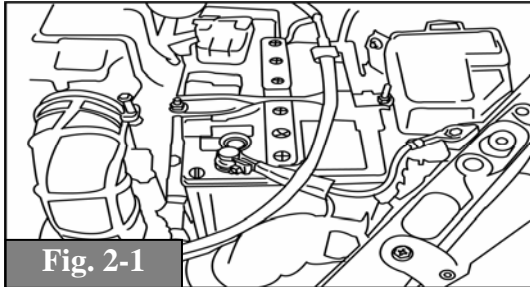



1. Pre-installation Precautions

-  (a) Use Seat & Floor Protectors and Fender Covers/Blankets to avoid damage to surfaces. Operator Safety Warning (if applicable.)

2. Battery Disconnect

-  (a) NOTE: Be sure to open the rear hatch, PRIOR to disconnecting the battery.
- (b) Remove the NEGATIVE (-) battery terminal using a 10mm socket before any disassembly starts. (Fig. 2-1).

3. Disassemble Center Instrument Panel (IP)

- (a) Starting with the center portion of the center IP, pull out the three (3) climate control knobs (Fig. 3-1)
- (b) Using the #2 Philips Screwdriver, remove the 2 screws behind the right & left side climate control knobs. (Fig. 3-2)
-  (c) Carefully pull out the center IP and carefully disconnect the connectors located behind. (Fig. 3-3 & 3-4)
 - (1) A NRT may be used to remove difficult connectors from center IP.
 -  (2) Place center IP, Pillars (and all interior panels) on a protected surface (i.e. blanket)

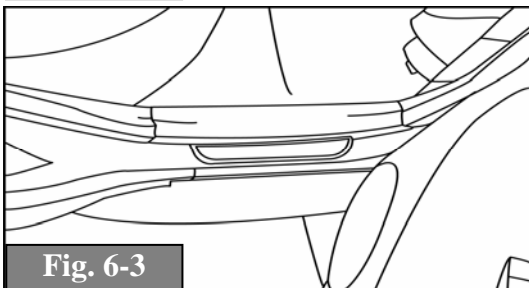
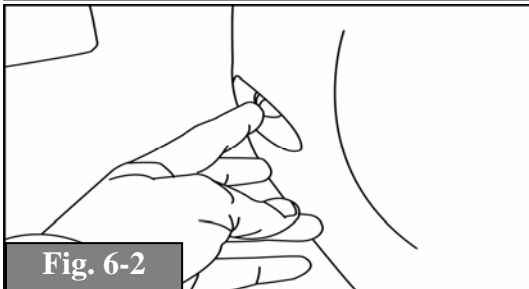
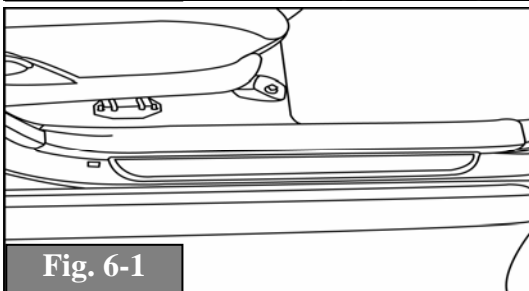
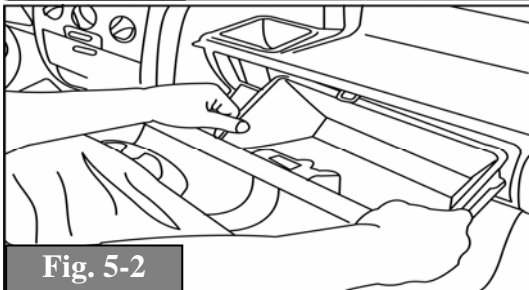
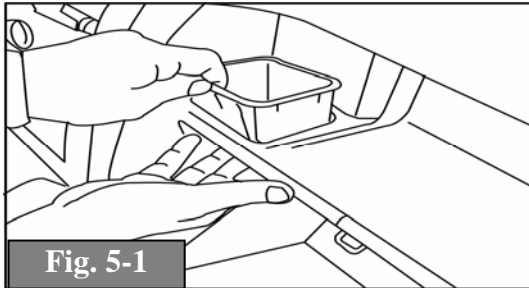
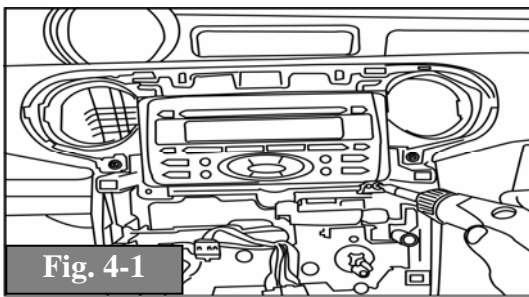

4. Remove Radio

- (a) With the center IP removed, use a #2 Philips Screwdriver to remove the four (4) screws from the radio bracket. (Fig. 4-1)
- (b) Pull out the Radio and carefully disconnect the connectors located behind.
 - (1) A NRT may be used to release difficult connectors from the radio.



- (2) Carefully place Radio on a protected surface (i.e. blanket)

5. Disassemble Glove Compartment

- (a) Open the glove compartment latch, and remove the storage cup. (Fig. 5-1)
- (b) Press the outside edges of the glove compartment inwards, to release. (Fig. 5-2)



- (1) Place glove compartment and storage cup on a protected surface (i.e. blanket)

6. Disassemble Passenger Front & Rear Scuff Plates, Passenger Kick Panel, & B-Pillar Panel

- (a) Using a NRT, remove passenger front scuff plate by carefully pulling upward. (Fig. 6-1)
- (b) Remove passenger kick panel by removing the plastic screw (located near firewall) & pulling out the kick panel. (Fig. 6-2)
- (c) Using a NRT, release the bottom portion of the B-Pillar panel and remove panel.



- (d) Using a NRT, remove rear passenger scuff plate by carefully pulling upward. (Fig. 6-3)

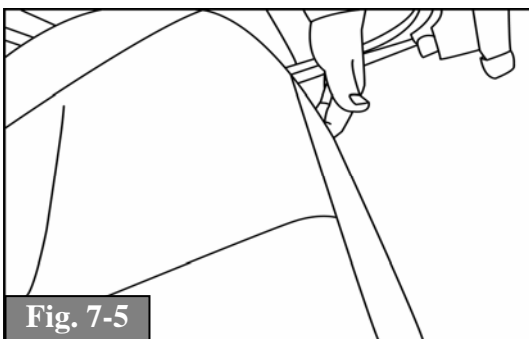
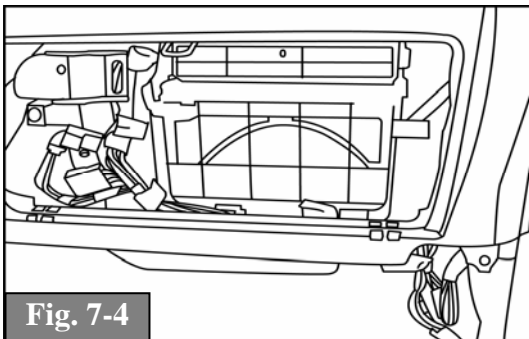
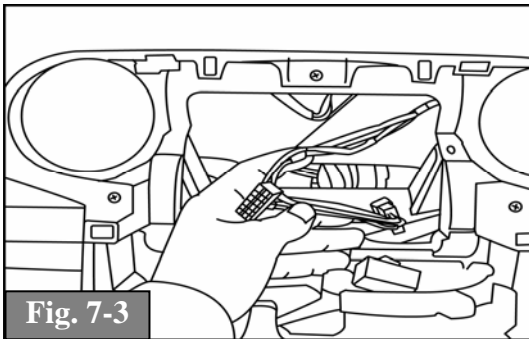
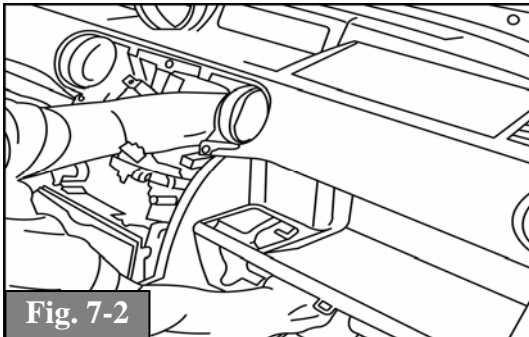
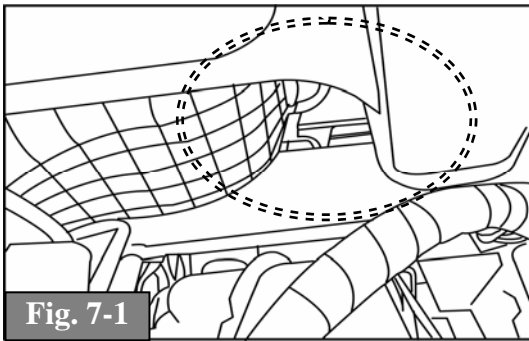

- (1) Place kick panel, and all scuff plates on a protected surface (i.e. blanket)



7. Route Wire Harness

- (a) Starting underneath the passenger foot-well, route the T-Harness portion of the wire harness through the opening above the center reinforcement rod as shown in Figure 7-1.
- (b) Reaching through the radio opening, pull the T-Harness connector from the backside of the dash, while advancing the wire harness from underneath the passenger foot-well. (Fig. 7-2)
- (c) Using one (1) 7" wire tie, secure the wire harness behind radio, onto an existing vehicle wire harness. (Fig. 7-3)
- (d) Using six (6) 7" wire ties, secure the wire harness at the 6 highlighted points. (Fig. 7-4)
 - (1)  Be sure the wire tie locations are far from moving parts or sharp edges. Ensure that the wire harness is tied tight enough to prevent it from moving or vibrating.
 - (2)  Using the diagonal cutter pliers, clip the seven (7) 7" wire ties.
- (e) Route the wire harness towards the rear of the vehicle, across the passenger front door well, behind the B-Pillar and across the passenger rear door well.
 - (1) Using the vehicle accommodated clips, secure the wire harness using the 4" wire ties. Use the included wire ties when vehicle clips are not present, to ensure that the wire harness is not loose.
- (f) Remove the rear bench seat by pulling upwards on each corner, to release the two (2) mounting clips. (Fig. 7-5)

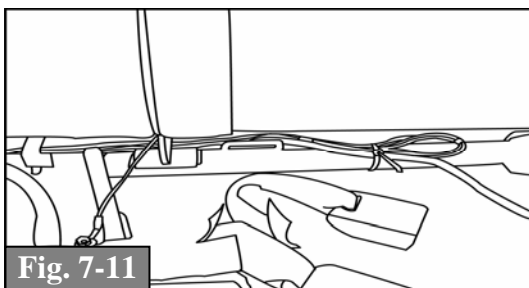
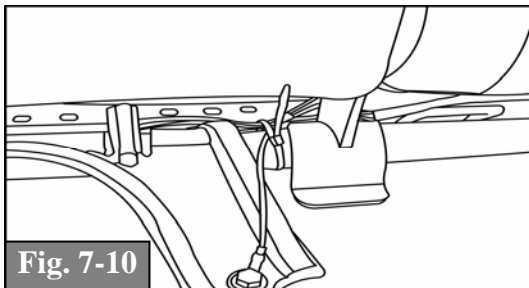
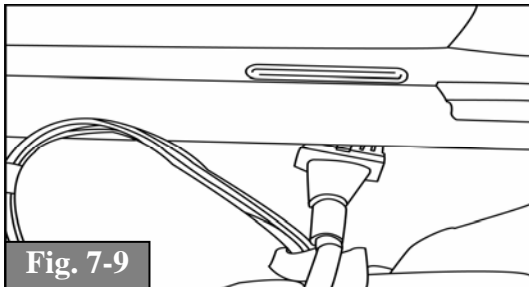
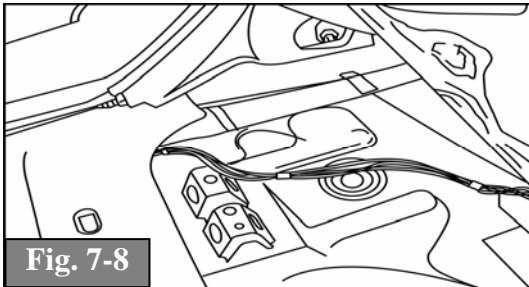
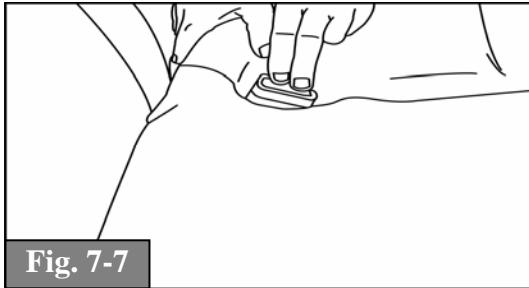
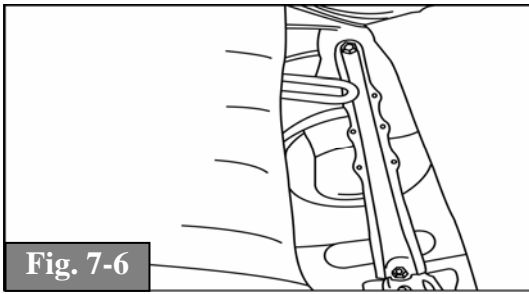

- (g) The rear bench must be “de-looped” from center safety loop and all seat belt latches need to be pushed through their respective slots. (Fig. 7-6 & 7-7)
- (h) Route the wire harness underneath the rear carpet as shown. (Fig. 7-8)
- (i) Route the 14 Pin Molex connector, underneath the rear seat pivot rod (under the #2 passenger side clip, nearest the center), and continue routing the wire harness to the right. (Fig. 7-9)
- (j) Using a 12mm socket, remove the center Anchorage bolt located on the middle mounting bracket and install the wire harness ground ring underneath the bolt.

- (1) Connect the ground ring to the hole just prior to routing the wire harness through the center pivot bracket. (Fig. 7-10)



- (2) Torque bolt to 10 lbf-ft

- (k) Collect any excess harness and wire-tie the wire harness to the rear seat pivot rod using three (3) 7” wire ties. (Fig. 7-11)



- (1) Using the diagonal cutter pliers, clip the three (3) 7” wire ties.

- (l) Route the 14 pin Molex connector behind the drivers’ side rear seat, into the rear cargo area.

8. Mounting the Bazooka Tube

NOTE: Paper (cargo panel) drill templates are included in every kit & are to be used for customer/DIO installation. PPO (cargo panel) drill templates have been supplied to the TLS facilities.

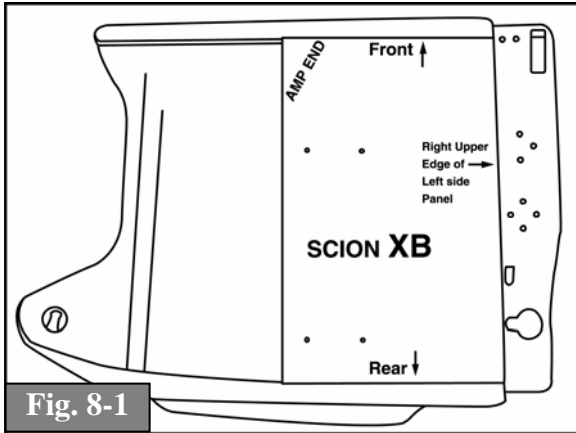

Fig. 8-1

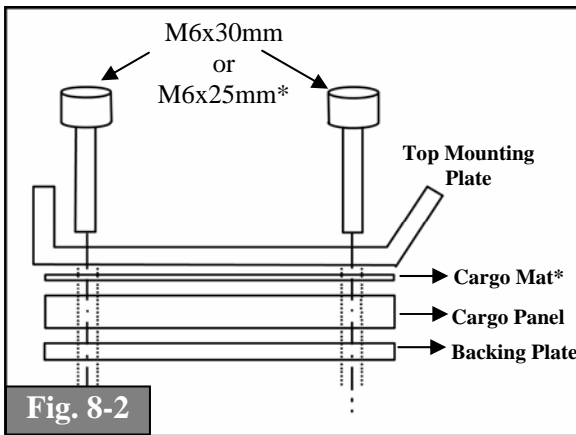

Fig. 8-2

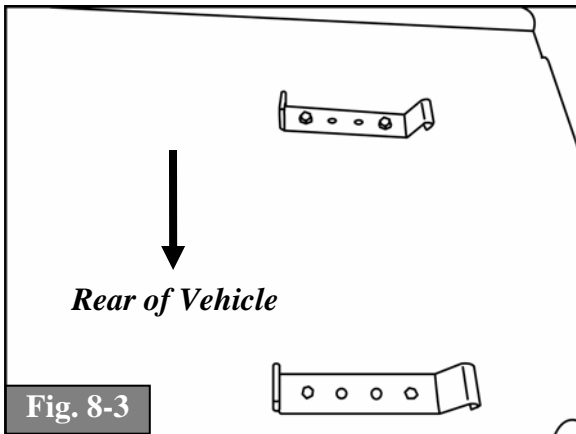

Fig. 8-3

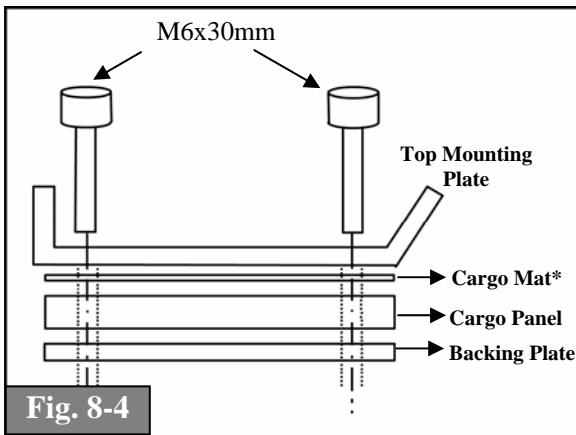

Fig. 8-4



(a) If vehicle is equipped with a rear cargo mat (PN: PT206-52043-02) remove the cargo mat at this time (Reference Step 9 (a))

(b) Remove the rear cargo panels from vehicle, by unlocking the 3 locking knobs, and lifting both panels out of the vehicle.



(c) Place the rear left (drivers side) panel onto a safe, & stable surface, where drilling is safe.

(d) Place the drill template onto the rear drivers' side cargo panel, aligning it over to the far right side profile of the panel. (Fig. 8-1)

(e) Using the 5/16" drill bit, drill the 4 allotted holes into the rear panel.

(1) Make sure the holes are drilled straight.



(2) Clean the cargo panel from any shavings or drill debris.



(3) If vehicle is equipped with the rear cargo mat, **DO NOT PROCEED** to the next step. Proceed to Step 9 (a) at this time, to prepare the rear cargo mat. If vehicle is not equipped with rear cargo mat, proceed to the next step (Step 8 (f))

(f) Starting on the 2 forward holes, place two (2) M6 x 30mm bolts through the two outside holes of the top mounting plate, (through the pre-punched cargo mat, if equipped), through the cargo panel, & into the threaded backing plate, located underneath the panel. (Fig. 8-2)



(1) If the vehicle is NOT equipped with a rear cargo mat, use the (2) M6 x 25mm bolts on the 2 forward holes.

(2) Position the "curled" side of the top mounting plate as shown in Fig. 8-3.

(g) On the rear 2 holes, place two (2) M6 x 30mm bolts through the two outside holes of

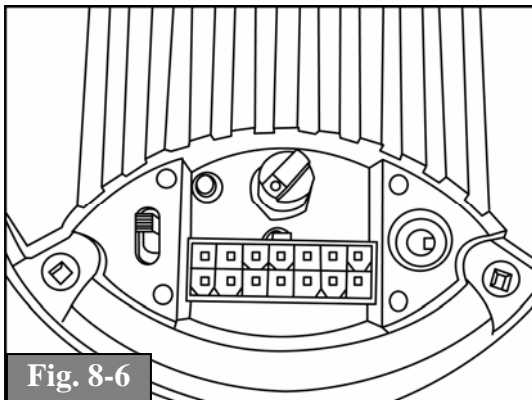
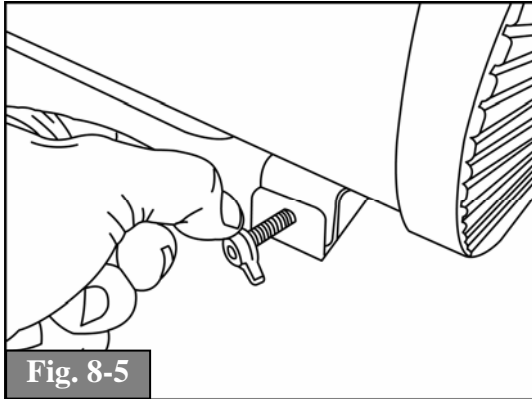

the top mounting plate, (through the pre-punched cargo mat – if equipped), through the cargo panel and into the threaded backing plate, located underneath the panel. (Fig. 8-4)

(1) Position the “curled” side of the top mounting plate as shown in Fig. 8-3.

(h) Securely tighten the four (4) M6 x 30mm Bolts using the 10 mm socket.

(i) Place the rear cargo panels back into the vehicle – do not lock panels at this time.

(j) Install the Bazoooka Tube by aligning the mounting brackets on the tube with the mounting plates on the panel.

(1) The screen portion of the tube must be facing the rear of the vehicle.

(k) Secure the Bazoooka tube mounting brackets to the mounting plates using the supplied mounting bracket knobs. (Fig. 8-5)

(l) Connect the Bazoooka to the Wire Harness by plugging the 14-pin Molex Connector (routed behind the rear drivers’ side seat) into the back of the Bazoooka.



(1) Confirm that the rotary knob (gain control) on the back of the unit is set completely counter-clockwise (until it can not be turned any further) & that the slide switch (phase) is in the up position. (Fig. 8-6)

(m) Re-Lock the cargo panel back into vehicle.

9. Preparing Rear Cargo Mat (if equipped)

NOTE: Paper (cargo mat) drill templates are included in every kit and are to be used to modify the rear cargo mat when used with the Bazoooka Subwoofer.

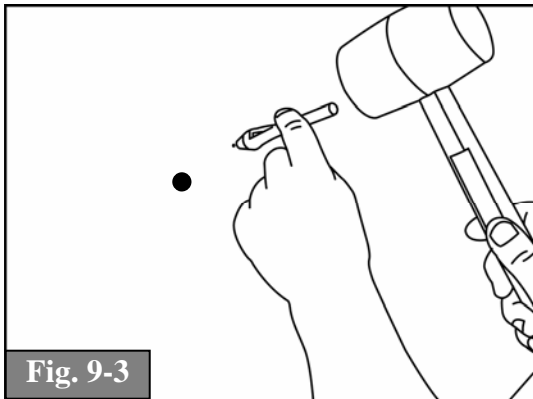
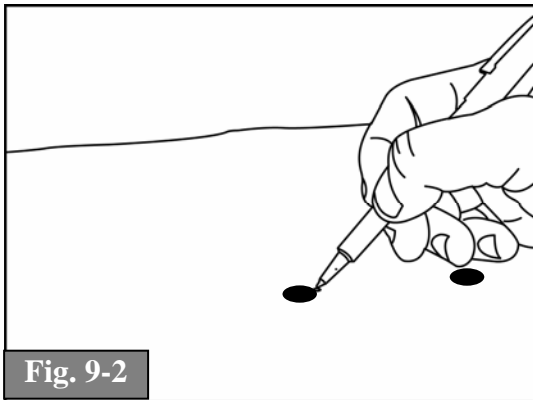
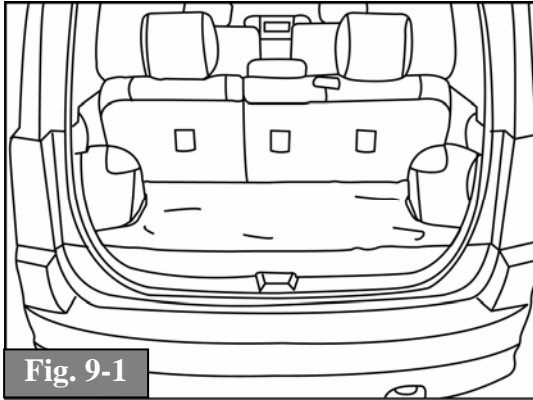

- (a) If vehicle is equipped with a rear cargo mat (PN:PT206-52043-02), the mat must be removed prior to drilling the rear cargo panel.



- (1) The cargo mat must be placed onto a safe, & stable surface, where punching is safe.



- (b) In order to prepare the rear cargo mat, the cargo panels must be drilled (Step 8 (e))
- (c) Once the cargo panel has been drilled place the panel back into the vehicle (Step 8. (i)); place the paper (cargo mat) drill template on top of the pre-drilled cargo panel. (Fig. 9-1)



- (1) Ensure that the paper (cargo mat) template sits within the same footprint as the cargo area.

- (2) Mark the four (4) drilled holes of the cargo panel, onto the paper template. (Fig. 9-2)

- (d) Once marked, remove the paper template, and place it over the cargo mat. Place the 5/16” Arch Punch over each marked spot, and punch four (4) holes (through the paper template & mat) using the rubber mallet. (Fig. 9-3)

- (e) Once the mat is punched, remove the panel from vehicle, & revert back to Step 8 (f).

10. Reassemble Rear Seat

- (a) Place rear seat back into vehicle, and “re-loop” center safety loop onto bracket.



- (b) Insert seat belt latches into their respective slots and ensure that the center seat belt latch is routed to its correct position. (Center latch is identified with a “CENTER” marking)

11. Reassemble Passenger Front & Rear Scuff Plates, Passenger Kick Panel, & B-Pillar Panel

- (a) Referencing Step 6 (a), reassemble all panels into their original locations, making sure that all clips are securely fastened.

12. Reassemble Glove Compartment

- (a) Referencing Step 5 (a), reassemble glove compartment & storage cup to its original location, making sure that all clips are securely fastened.

13. Reassemble Radio

- (a) Referencing Step 4 (a), reassemble the Radio by connecting: 1) T-Harness into the back of the Radio 2) the Satellite harness (if equipped) and 3) the radio antenna cable. (Fig. 13-1)
- (b) Carefully insert Radio back into center IP opening, by aligning mounting holes to the radio bracket. Be sure the wire harness is not pinched.

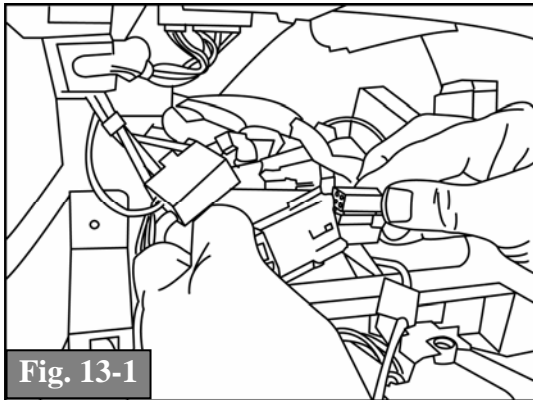

Fig. 13-1



- (1) Securely fasten (hand tight) the four (4) mounting screws using the #2 Philips Screwdriver. DO NOT OVERTIGHTEN

14. Reassemble Center Instrument Panel (IP)

- (a) Referencing Step 3 (a), carefully reconnect all the vehicle connectors back onto the center IP.
- (b) Insert the center IP back onto the dash assembly by carefully inserting the top alignment tabs of the center IP into the dash assembly.
- (c) Once tabs are secured, then apply pressure to the perimeter of the center IP until it is flush with the dash assembly.

15. Reconnect Battery

-  (a) Using a 10 mm socket, reconnect the NEGATIVE (-) battery terminal at a 45-degree angle and torque to 36 lbf·in

16. Test and Set Up Procedures

- (a) If system is installed correctly, the Bazooka Tube will power up when the vehicle's ignition is turned on. (This can be confirmed by the lighting of the POWER L.E.D. on the back of the unit.) (Fig. 16-1)



- (b) Before proceeding, ensure that the Phase Switch is in the "UP" Position. (Fig. 8-6)

- (1) **NOTE:** Bazooka Tube will not function if the Phase Switch is in the down position.

- (c) Using the tone controls on the radio, adjust the balance left and right, to verify that Bazooka Tube produces sound on both sides, and that the sound is loudest when the balance is set to the center. (Fig. 16-2)

- (d) Tune to a radio station or CD, and adjust volume to a comfortable listening level. (If the sound is distorted, adjust the gain control knob counter-clockwise (-) until the Bazooka Tube produces clean sound. If the unit cannot be heard, adjust the gain control clockwise (+) until sufficient output is achieved.) (Fig. 16-3)

- (e) Lowering the rear drivers' seat allows easy access to the gain control knob.

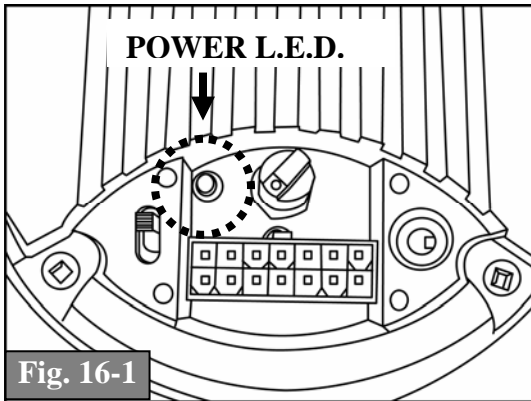

Fig. 16-1

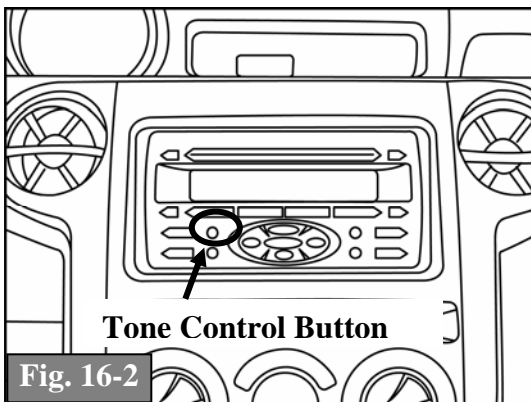

Fig. 16-2

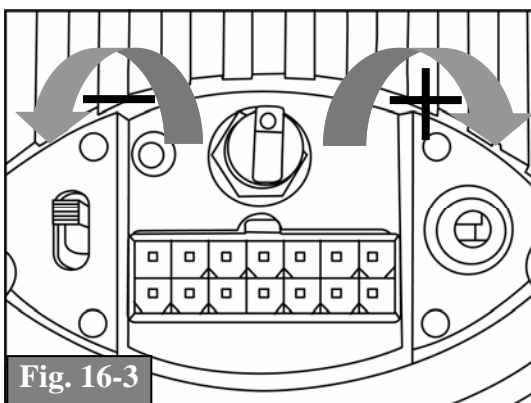

Fig. 16-3

17. Clean Up

(a) If required, wipe down all applicable interior surfaces with 3MTM Prep Solvent-70, to remove fingerprints, etc.

(b) When cleaning with 3MTM Prep Solvent-70:



(1) Always use a clean (lint free, scratch resistant) soft cloth (or wipe), and clean a small area at a time (~ 3 ft. x 3 ft. max.).

(2) **Shake Well.**



(3) Apply 3M™ Prep Solvent-70 to cloth or wipe. Do not spray cleaning solutions directly to **any** vehicle surfaces.

(4) Clean surface thoroughly and wipe dry immediately with a new clean cloth. Do not allow cleaner to air dry.



(c) Place Care Card **AND** Installation Instructions in Glove Compartment.

(d) Remove protective covers from vehicle interior.

Checklist - these points **MUST** be checked to ensure a quality installation.

Check:	Look For:
<p><u>Accessory Function Checks</u></p> <ul style="list-style-type: none"> <input type="checkbox"/> Turn on Radio <input type="checkbox"/> Verify CD & Satellite Tuner (if equipped) <input type="checkbox"/> Antenna is functioning <input type="checkbox"/> Bazooka Tube operation 	<p>Radio display turns on & sound is heard</p> <p>CD player functions & Satellite Tuner stations are playing (if equipped)</p> <p>Reception of AM/FM stations</p> <p>Bazooka Tube – Listen to Bazooka Tube to make sure it is functioning properly or by feeling the Bazooka for vibration. Be sure the Phase Switch is in the “UP” position.</p>
<p><u>Vehicle Function Checks</u></p> <ul style="list-style-type: none"> <input type="checkbox"/> Hazard Button <input type="checkbox"/> HVAC <input type="checkbox"/> Rear Window Defogger <input type="checkbox"/> Passenger Seat Belt Warning Light 	<p>Functioning Hazard Lights</p> <p>All HVAC controls function properly</p> <p>Functioning Rear Window Defogger</p> <p>Functioning Seat Belt Warning Light</p>



Troubleshooting

Condition:

No sound from Bass Tube, however factory speakers still play

Distorted Sound

Low Sound

Rattling Noises

Check For:

1. Is the green L.E.D. lit on the Bass Tube? If not, check for 12 volts on pins of the Bass Tube Connector with the ignition on. If either pin doesn't indicate 12 volts, check T-Harness connectors behind the radio.

2. Is the 14-pin Molex connector securely connected to the Bass Tube?

3. Is the ground ring securely fastened to the rear center Anchorage bolt?

1. Close the back hatch of the vehicle

2. Adjust the radio to a comfortable listening level, and then turn the "gain control" knob on the Bass Tube counter-clockwise until the sound becomes clean.

1. Close the back hatch of the vehicle

2. Adjust the radio to a comfortable listening level, and then turn the "gain control" knob on the Bass Tube clockwise until the sound becomes audible. Do not adjust the level too high, as this will result in distorted sound.

Rattling will be evident in some panels at extreme volume conditions, but make sure you have performed the following to minimize noise:

1. Securely tightened Mounting Hardware so Bass Tube Bracket does not move.



Troubleshooting

Condition: _____

- Dimming Radio Lights

- Radio does not come on

- No Sound at all

- Bass Tube produces sound on the right or the left, but not both.

Check For: _____

Dimming Radio Lights could occur when the Bass Tube is played at high volumes.

Check to ensure that the main connector, antenna connector, and auxiliary connector have been correctly plugged back in.

1. Is the fuse under the hood still operational?
2. Is the battery ground reconnected?
3. Is the radio connector securely seated?

Check T-Harness connections at the back of the radio. All connectors must be securely fastened to the correct wiring for both channels to produce audio output.



Wire Harness & Radio Wiring Schematics

WIRING CONNECTOR SCHEMATICS:		
Harness Split	Radio Connector	Subwoofer Connector
Harness Split Connector		
Pin No.	Wire Color	Function
1	Red	12 Volt Battery Connection (B+)
2	White/Black	Left Front Speaker (-)
3	Gray/Black	Right Front Speaker (-)
4	Blue/White	Remote Turn-On/Ignition (Switched+)
5	White	Left Front Speaker (+)
6	Gray	Right Front Speaker (+)
Subwoofer Connector		
Pin No.	Wire Color	Function
1	Black	Chassis Ground
2	N/A	N/A
3	N/A	N/A
4	N/A	N/A
5	White	Left Front Speaker (+)
6	Grey	Right Front Speaker (+)
7	N/A	N/A
8	Red	12 Volt Battery Connection (B+)
9	Blue/White	Remote Turn-On/Ignition (Switched+)
10	N/A	N/A
11	N/A	N/A
12	White/Black	Left Front Speaker (-)
13	Grey/Black	Right Front Speaker (-)
14	N/A	N/A
Radio Connector (R4 GRAY)		
Pin No.	Wire Color	Function
1		Right Front Speaker (+)
2		Left Front Speaker (+)
3	NO CONNECTION	NO CONNECTION
4	NO CONNECTION	NO CONNECTION
5		12 Volt Ignition Switched (B+)
6		12 Volt Battery Connection (B+)
7		Right Front Speaker (-)
8		Left Front Speaker (-)
9		Chassis Ground (B-)
10		Power Antenna Control (+)
11		Power Antenna Control (-)
12		Dimmer / Illumination Control (B+ variable)