

AIR CONDITIONING AMPLIFIER

COMPONENTS

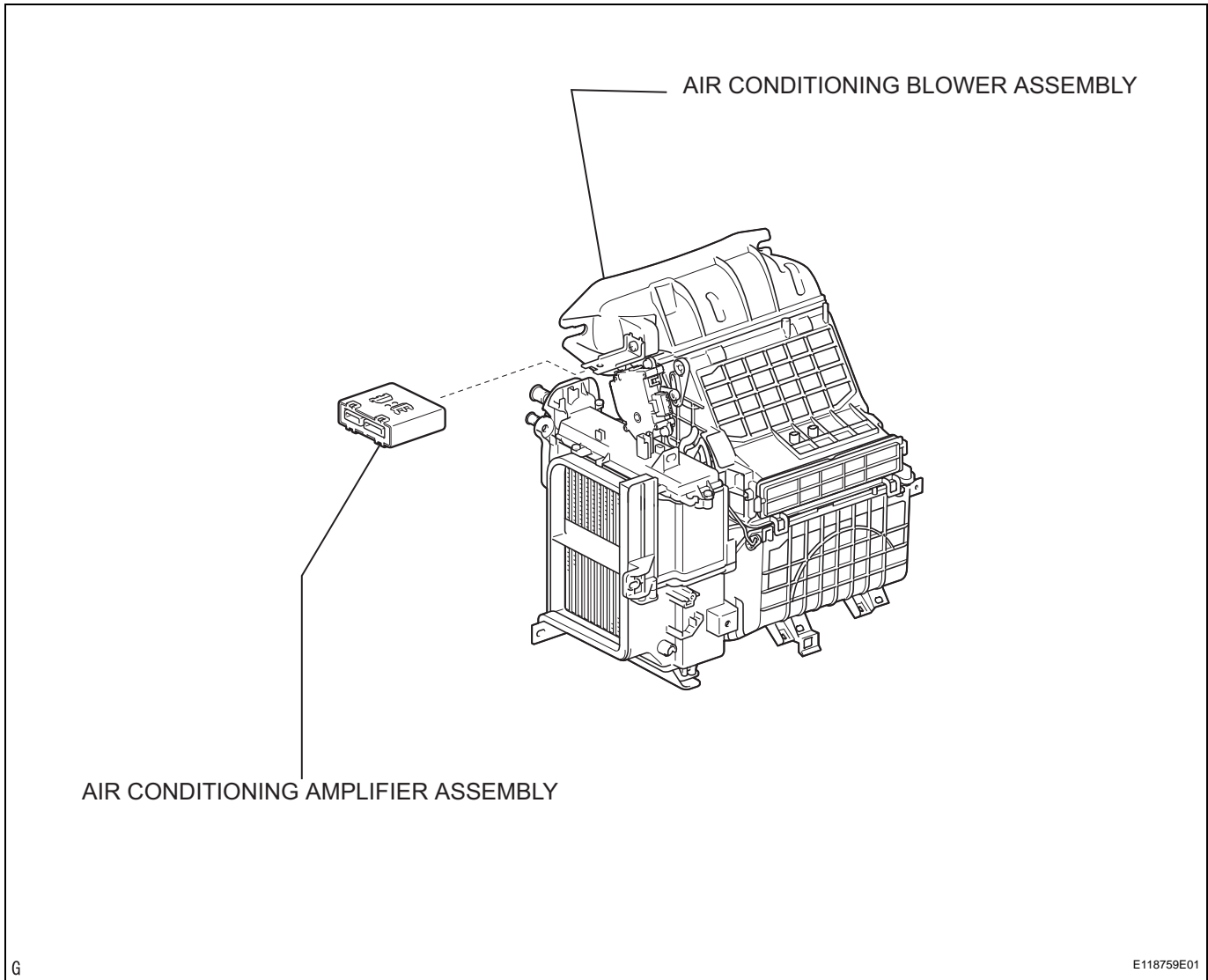

G

E118759E01

REMOVAL

1. **DISCONNECT CABLE FROM NEGATIVE BATTERY TERMINAL**
CAUTION:
Wait at least 90 seconds after disconnecting the cable from the negative (-) battery terminal to prevent airbag and seat belt pretensioner activation.
2. **REMOVE HEATER CONTROL KNOB** (See page [IP-5](#))
3. **REMOVE INSTRUMENT CLUSTER FINISH PANEL CENTER** (See page [IP-6](#))
4. **REMOVE RADIO RECEIVER ASSEMBLY**
5. **REMOVE AIR CONDITIONING AMPLIFIER ASSEMBLY**
 - (a) Disconnect the connector.
 - (b) Detach the claw and remove the A/C amplifier.

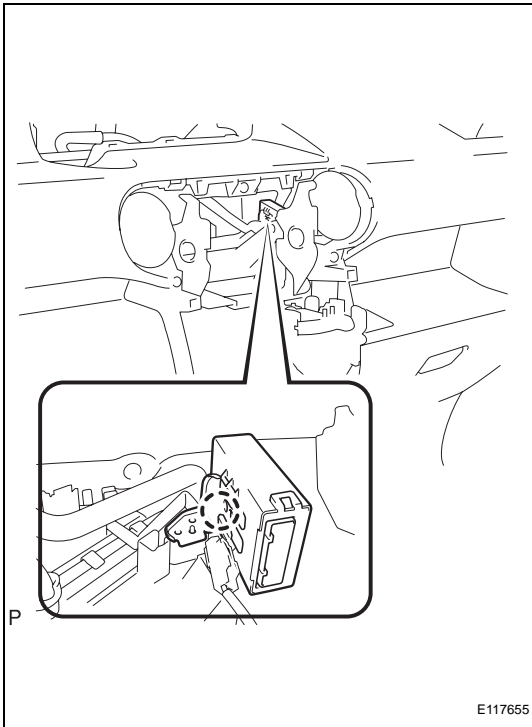

INSTALLATION

1. **INSTALL AIR CONDITIONING AMPLIFIER ASSEMBLY**
 - (a) Attach the claw to install the A/C amplifier.
 - (b) Connect the connector.
2. **INSTALL RADIO RECEIVER ASSEMBLY**
3. **INSTALL INSTRUMENT CLUSTER FINISH PANEL CENTER (See page [IP-12](#))**
4. **INSTALL HEATER CONTROL KNOB (See page [IP-13](#))**
5. **CONNECT CABLE TO NEGATIVE BATTERY TERMINAL**

