

# BRAKE BOOSTER

## COMPONENTS

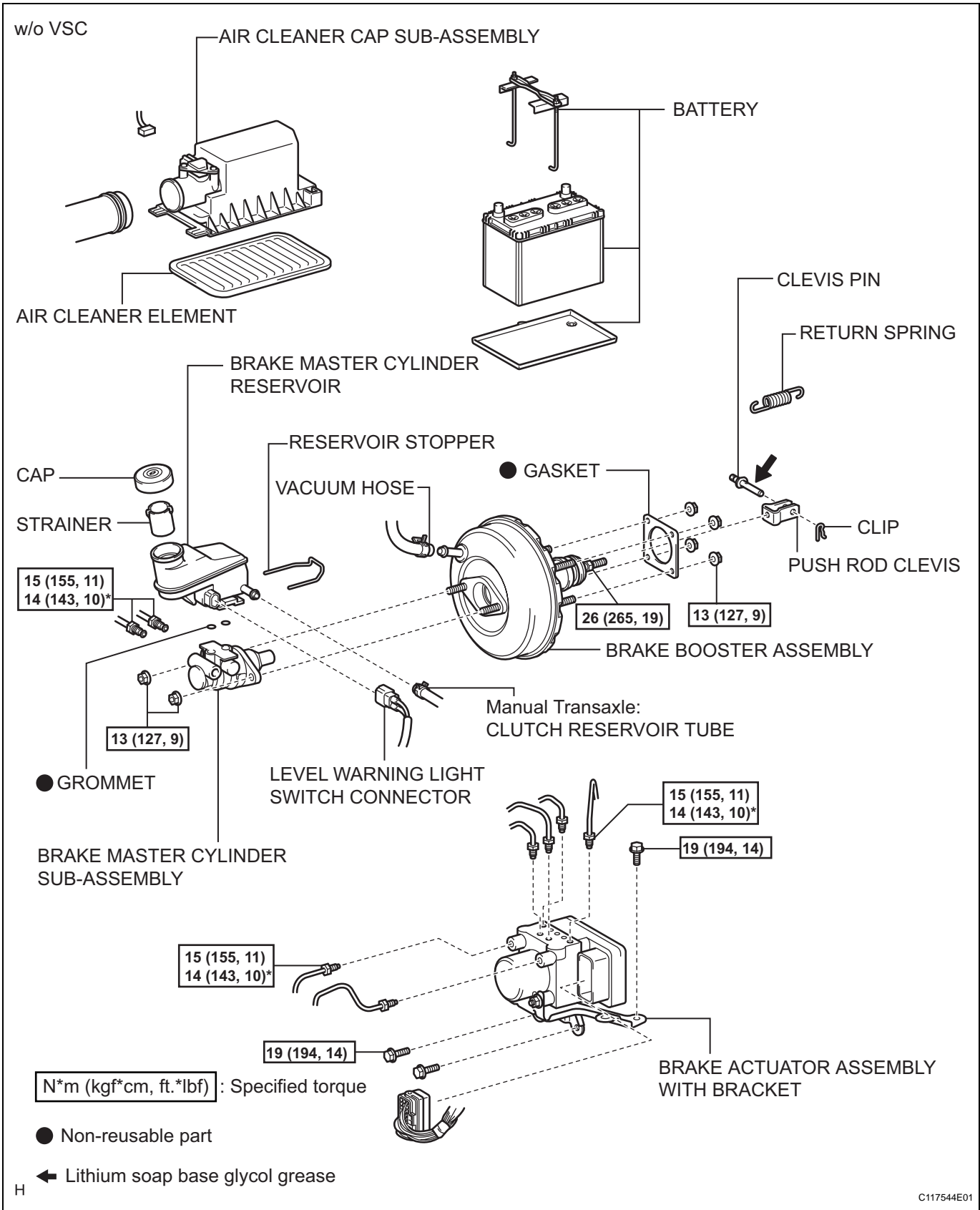

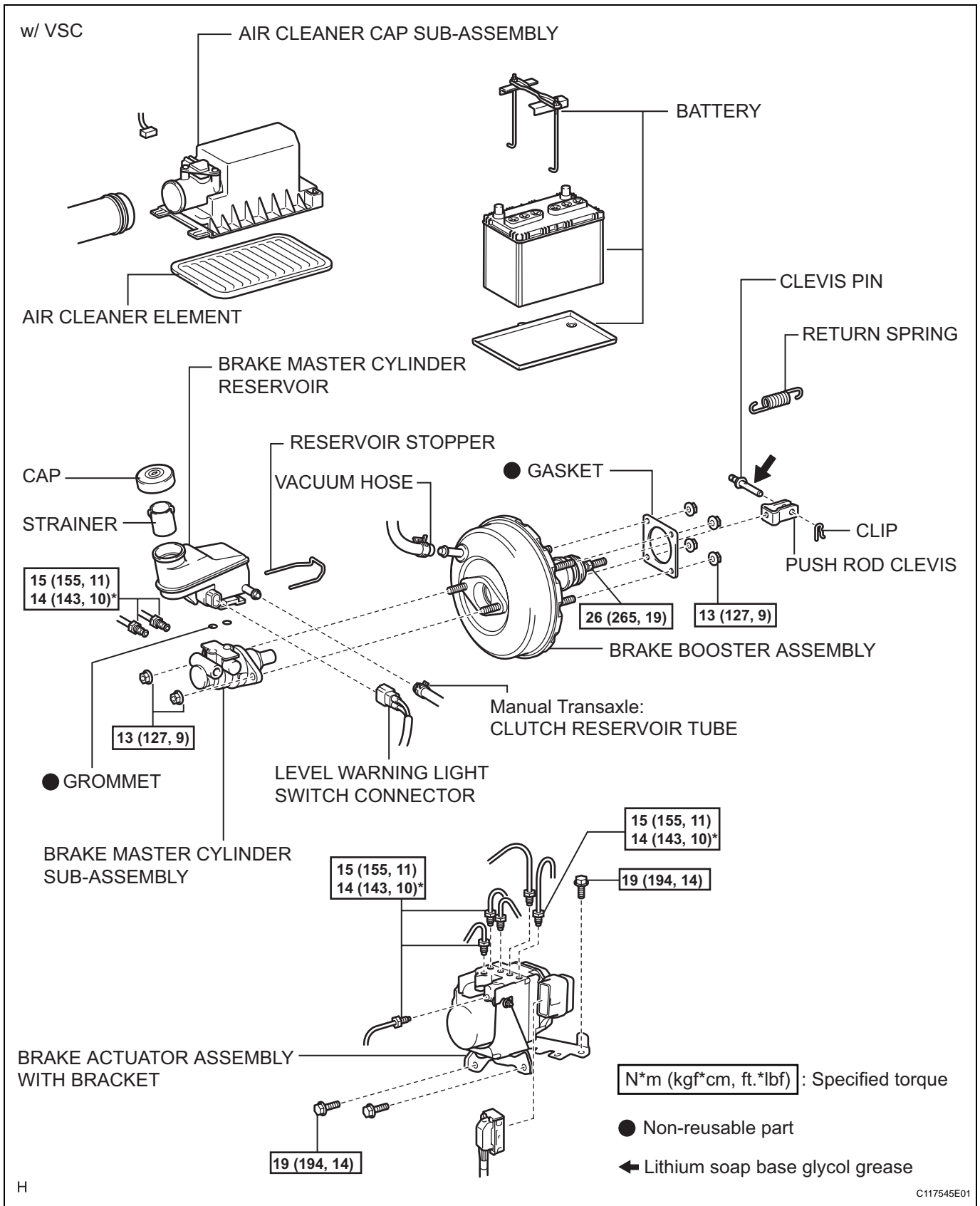

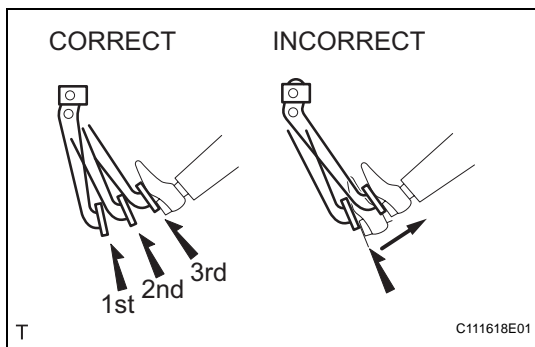

## ON-VEHICLE INSPECTION

### 1. CHECK BRAKE BOOSTER ASSEMBLY

- (a) Airtightness check.
- (1) Start the engine and stop it after 1 or 2 minutes. Depress the brake pedal several times slowly.
  - (2) Make sure the booster is airtight. Check that the distance the pedal can be depressed decreases gradually in correlation with each subsequent press of the pedal.  
If the pedal is not as specified, check the check valve.  
If the check valve is normal, replace the booster.
  - (3) Start the engine. Depress and hold down the pedal, and stop the engine.
  - (4) Make sure the booster is airtight. Hold the pedal for 30 seconds and check that there is no change in the pedal reserve distance.  
If the pedal is not as specified, check the check valve.  
If the check valve is normal, replace the booster.

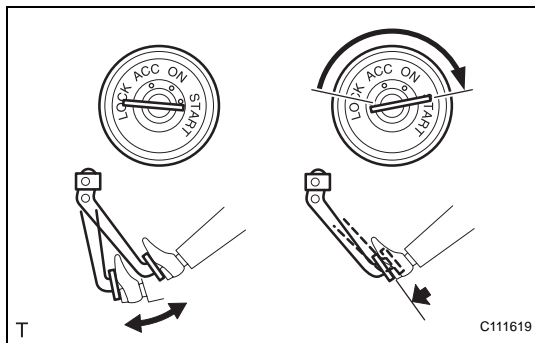

- (b) Operation check.
- (1) Depress the pedal several times with the ignition switch OFF and check that there is no change in the pedal reserve distance.
  - (2) Depress and hold down the pedal, and start the engine. Check that the pedal can only be depressed slightly.  
If the pedal is not as specified, check the check valve.  
If the check valve is normal, replace the booster.

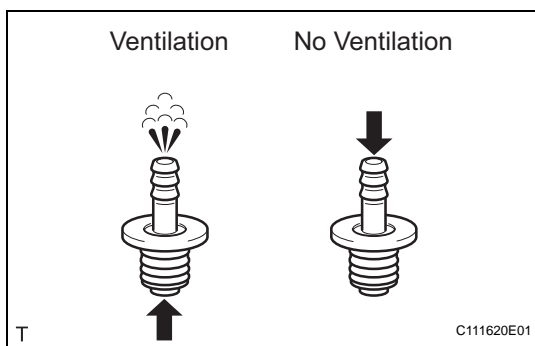

### 2. CHECK BRAKE VACUUM CHECK VALVE ASSEMBLY

- (a) Check the check valve.
- (1) Slide the clip and disconnect the vacuum hose.
  - (2) Remove the check valve from the booster.
  - (3) Check that there is ventilation from the booster to the engine, and no ventilation from the engine to the booster.  
If the results are not as specified, replace the check valve.