

BRAKE FLUID

BLEEDING

HINT:

If any work is performed on the brake system or if air in the brake lines is suspected, bleed air from the brake system.

NOTICE:

Wash off brake fluid immediately if it comes in contact with any painted surface.

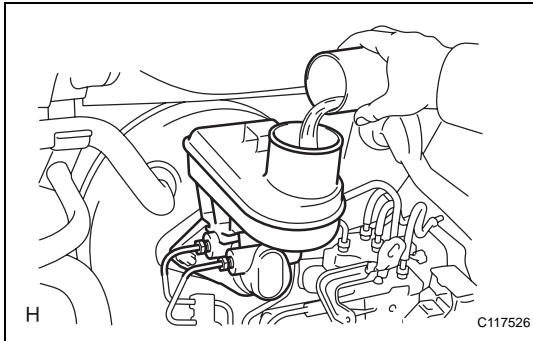

1. FILL RESERVOIR WITH BRAKE FLUID

Fluid:

SAE J1703 or FMVSS No. 116 DOT3

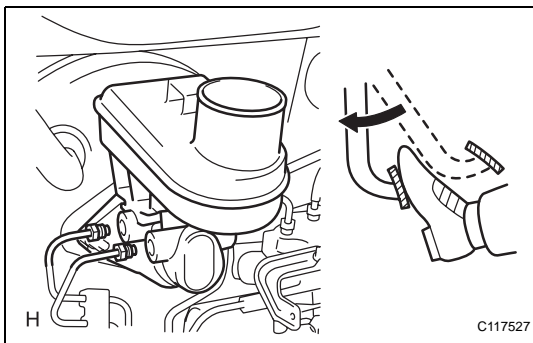

2. BLEED AIR FROM BRAKE MASTER CYLINDER

HINT:

If the master cylinder has been disassembled or if the reservoir becomes empty, bleed air from the master cylinder.

- (a) Using SST, disconnect the brake lines from the master cylinder.

SST 09023-00101

- (b) Slowly depress and hold the brake pedal.

- (c) Cover the outer holes with your fingers, and release the pedal.

- (d) Repeat the 2 previous steps 3 or 4 times.

- (e) Using SST, connect the brake lines to the master cylinder.

SST 09023-00101

Torque: 15 N*m (155 kgf*cm, 11 ft.*lbf) without SST

14 N*m (143 kgf*cm, 10 ft.*lbf) with SST

HINT:

Use a torque wrench with a fulcrum length of 30 cm (11.81 in.).

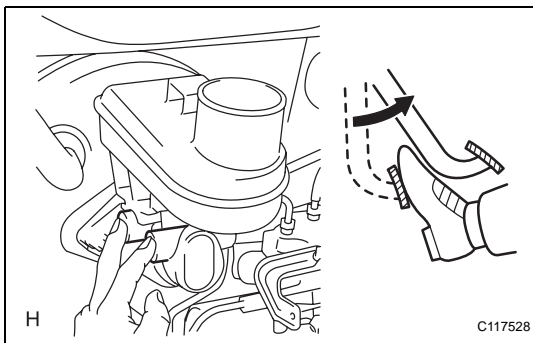

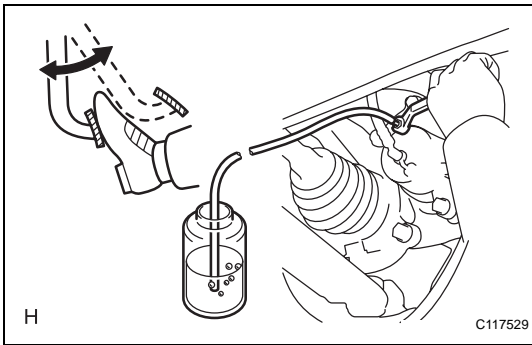

3. BLEED AIR FROM BRAKE LINE

- (a) Remove the bleeder plug cap.
- (b) Connect a vinyl tube to one of the bleeder plugs.
- (c) Depress the pedal several times, and then loosen the bleeder plug with the pedal depressed.
- (d) When fluid stops coming out, immediately tighten the bleeder plug. Then release the pedal.
- (e) Repeat the 2 previous steps until all the air in the fluid is gone.
- (f) Tighten the bleeder plug.
Torque: 8.3 N*m (85 kgf*cm, 73 in.*lbf)
- (g) Install the cap.
- (h) Bleed air from the brake line for each wheel by repeating the above procedures.

4. BLEED AIR FROM BRAKE ACTUATOR (w/ VSC)

NOTICE:

- After bleeding air from the brake system, the height and/or feel of the pedal may still be awkward. If so, use the intelligent tester to bleed air from the actuator.
- Perform the air bleeding by following the steps displayed on the intelligent tester.
- Make sure that the fluid in the reservoir does not become empty.

- (a) With the engine stopped, depress the pedal more than 20 times.
- (b) Connect the intelligent tester (with CAN VIM) to the DLC3, and then turn the ignition switch ON.

NOTICE: Do not start the engine.

- (c) Select "AIR BLEEDING" on the intelligent tester.

HINT:

Please refer to the intelligent tester operator's manual for further details.

- (d) Bleed air from the brake line in "Step 1: Increase" on the intelligent tester display.

- (1) Remove the bleeder plug cap.

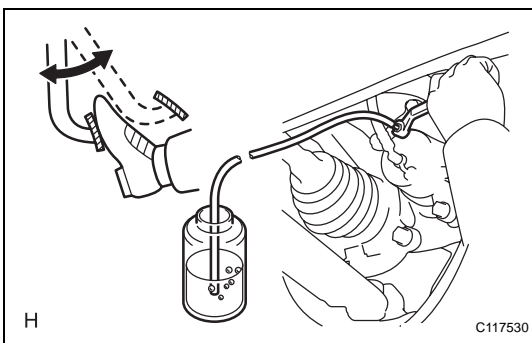
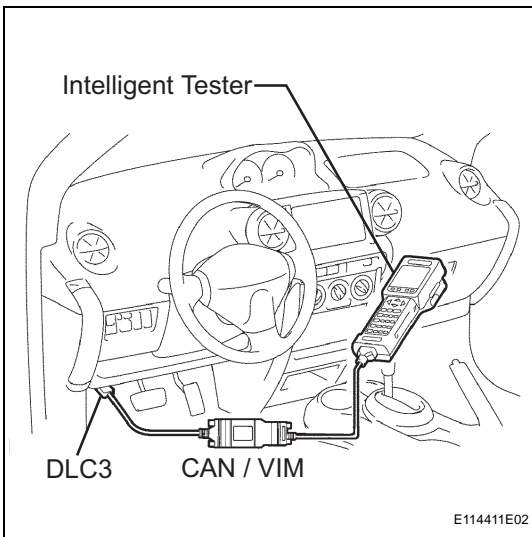

- (2) Connect a vinyl tube to either one of the bleeder plugs.

- (3) Depress the pedal several times, and then loosen the bleeder plug with the pedal depressed.

- (4) When fluid stops coming out, immediately tighten the bleeder plug. Then release the pedal.

- (5) Repeat the 2 previous steps until all the air in the fluid is gone.

- (6) Tighten the bleeder plug.
Torque: 8.3 N*m (85 kgf*cm, 73 in.*lbf)
- (7) Install the cap.
- (8) Repeat the 7 previous steps to bleed air from the brake line for each wheel.
- (e) Bleed air from the suction line in "Step 2: Inhalation" on the intelligent tester display.
 - (1) Remove the bleeder plug cap.
 - (2) Connect a vinyl tube to the bleeder plug at the right front wheel or the right rear wheel and loosen the bleeder plug.
 - (3) Using the intelligent tester, operate the actuator to bleed the air.
NOTICE:
The operation stops automatically in 4 seconds. At this time, be sure to release the pedal.
 - (4) View the intelligent tester display and check that the operation has stopped.
 - (5) Repeat the 2 previous steps until all the air in the fluid is gone.
 - (6) Tighten the bleeder plug.
Torque: 8.3 N*m (85 kgf*cm, 73 in.*lbf)
 - (7) Install the cap.
 - (8) Repeat the 7 previous steps to bleed air from the brake line for each wheel.
- (f) Bleed air from the pressure reduction line in "Step 3: Decrease" on the intelligent tester display.
 - (1) Remove the bleeder plug cap.
 - (2) Connect a vinyl tube to either one of the bleeder plugs.
 - (3) Loosen the bleeder plug.
 - (4) Using the intelligent tester, operate the actuator. At the same time, depress the pedal and maintain this position.
NOTICE:
 - **The operation stops automatically in 4 seconds. When performing this procedure continuously, an interval of at least 20 seconds is required.**
 - **When the operation is completed, the pedal slightly goes down. This is normal and it occurs when the solenoid opens.**
 - **During this procedure, the pedal may seem heavy, but completely depress it so that the fluid comes out from the bleeder plug.**
 - **Be sure to keep depressing the pedal. Never depress and release the pedal repeatedly.**
 - (5) Tighten the bleeder plug, and then release the pedal.
Torque: 8.3 N*m (85 kgf*cm, 73 in.*lbf)

- (6) Repeat the 3 previous steps until all the air in the fluid is gone.
- (7) Install the cap.
- (8) Repeat the 7 previous steps to bleed air from the brake line for each wheel.
- (g) Bleed air from the brake line again in "Step 4: Increase" on the intelligent tester display.
 - (1) Remove the bleeder plug cap.
 - (2) Connect a vinyl tube to one of the bleeder plugs.
 - (3) Depress the pedal several times, and then loosen the bleeder plug with the pedal depressed.
 - (4) When fluid stops coming out, immediately tighten the bleeder plug. Then release the pedal.
 - (5) Repeat the 2 previous steps until all the air in the fluid is gone.
 - (6) Tighten the bleeder plug.
Torque: 8.3 N*m (85 kgf*cm, 73 in.*lbf)
 - (7) Install the cap.
 - (8) Repeat the 7 previous steps to bleed air from the brake line for each wheel.

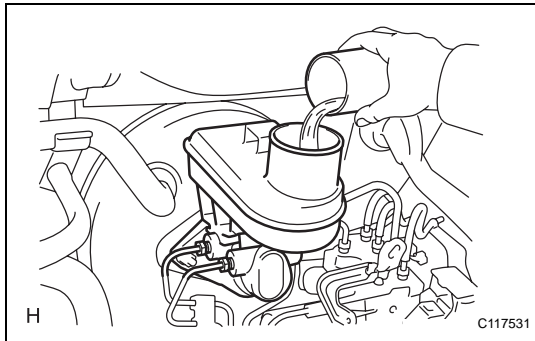
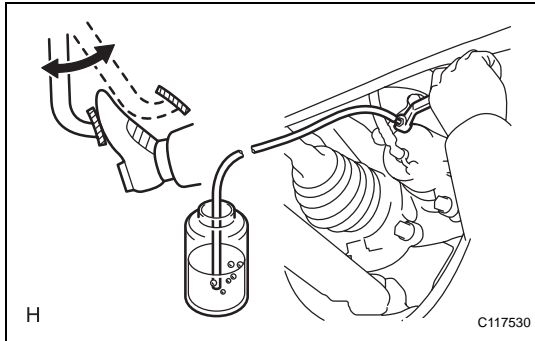

5. CHECK BRAKE FLUID LEVEL IN RESERVOIR

- (a) Check the fluid level. If necessary, add fluid.

Fluid:

SAE J1703 or FMVSS No. 116 DOT3