

# SYSTEM DIAGRAM

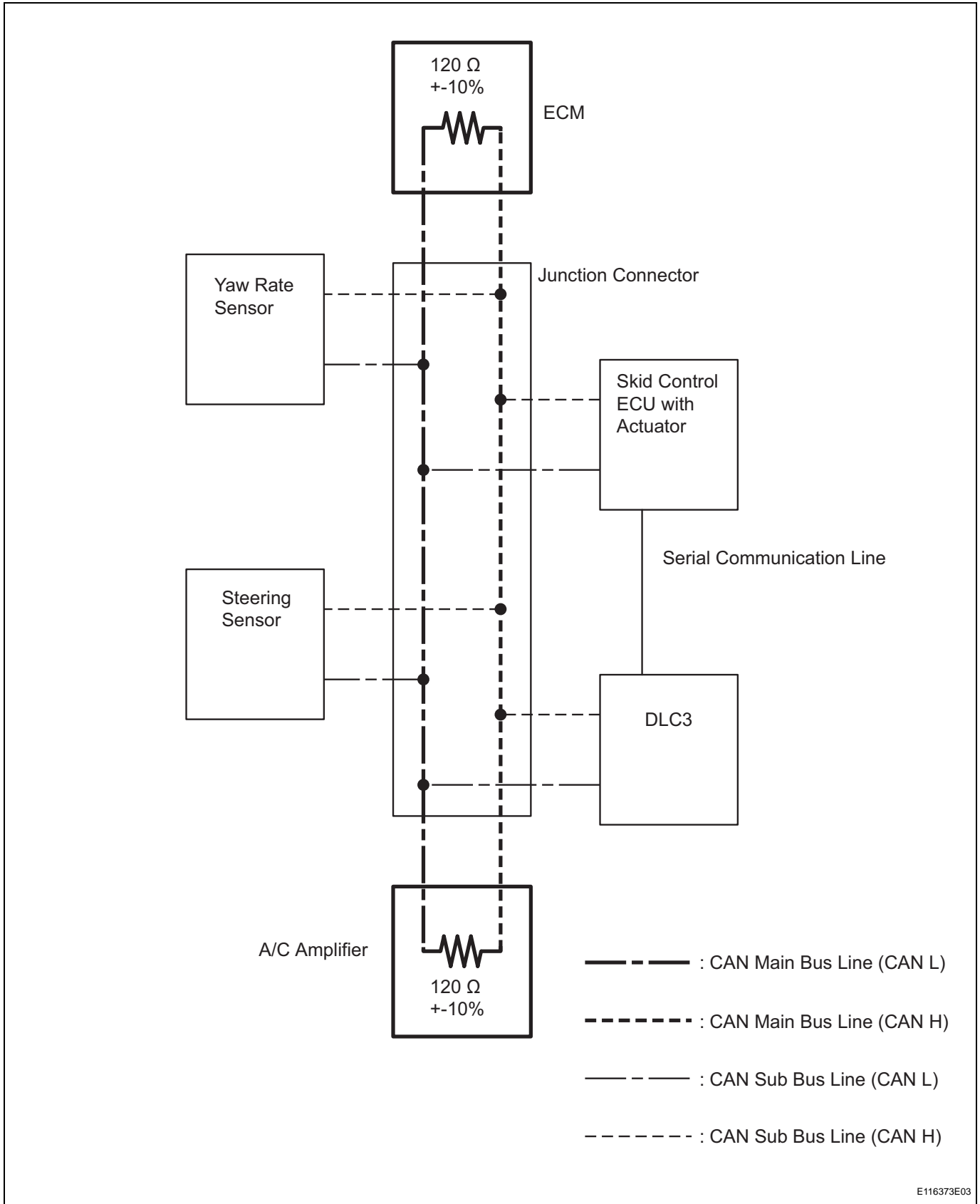

CA

**HINT:**

The skid control ECU stores DTCs and performs DTC communication by receiving information from the steering sensor and yaw rate sensor. These sensors cannot store DTCs or perform DTC communication.