

INSTALLATION

HINT:

When installing the name plate, heat the vehicle body and name plate using a heat light.

Standard heating temperature

Item	Temperature
Vehicle body	40 to 60°C (104 to 140°F)
Name plate	20 to 30°C (68 to 86°F)

NOTICE:

Do not heat the vehicle body and name plate excessively.

1. INSTALL NO. 2 BACK DOOR NAME PLATE

- (a) Clean the vehicle body surface.
 - (1) Using a heat light, heat the vehicle body surface.
 - (2) Remove the double-sided tape from the vehicle body.
 - (3) Wipe off any tape adhesive residue with white gasoline.
- (b) If reusing the name plate:

Clean the name plate.

 - (1) Using a heat light, heat the name plate.
 - (2) Remove the double-sided tape from the name plate.
 - (3) Wipe off any tape adhesive residue with white gasoline.
 - (4) Apply new double-sided tape to the name plate.
- (c) Install the name plate.
 - (1) Using a heat light, heat the vehicle body and name plate.
 - (2) Remove the peeling paper from the face of the name plate.

HINT:

After removing the peeling paper, keep the exposed adhesive free from foreign matter.

- (3) Install the name plate.

NOTICE:

Install the name plate exactly according to the specifications below.

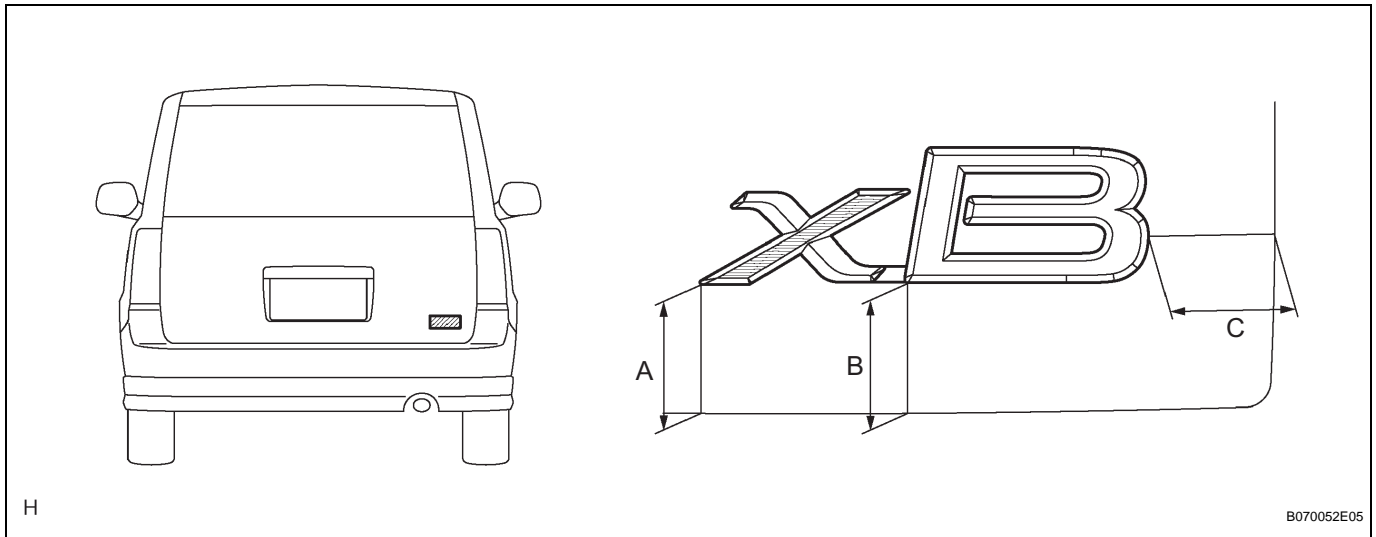

H

B070052E05

Standard measurement

Area	Measurement
A	163.9 mm (6.453 in.)
B	164.3 mm (6.468 in.)
C	61.7 mm (2.429 in.)