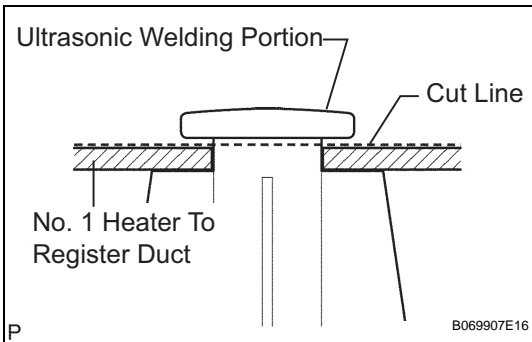
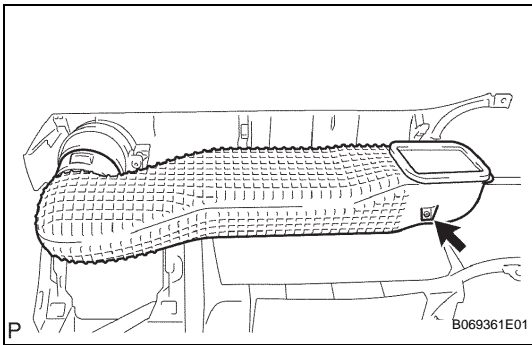
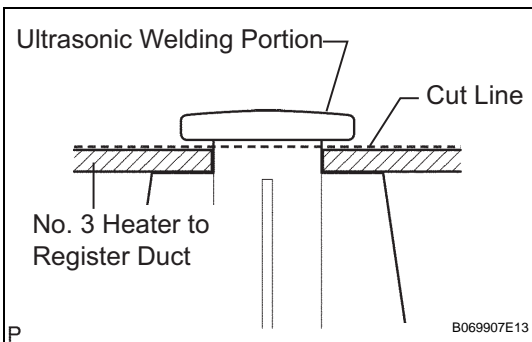
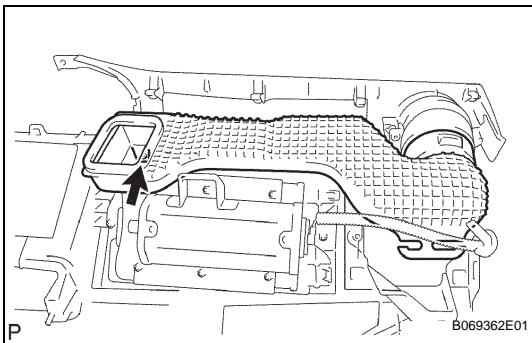

**DISASSEMBLY****1. REMOVE NO. 1 HEATER TO REGISTER DUCT**

- (a) Using nippers, cut off the ultrasonic welding portion as shown in the illustration to remove the No. 1 heater to register duct from the instrument panel.

**2. REMOVE NO. 3 HEATER TO REGISTER DUCT**

- (a) Using nippers, cut off the ultrasonic welding portion as shown in the illustration to remove the No. 3 heater to register duct from the instrument panel.

**3. REMOVE NO. 1 INSTRUMENT PANEL REGISTER ASSEMBLY**

- (a) Using nippers, cut off the ultrasonic welding portion as shown in the illustration to remove the No. 1 instrument panel register from the instrument panel.

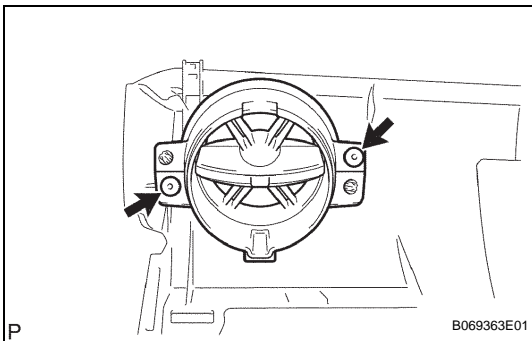

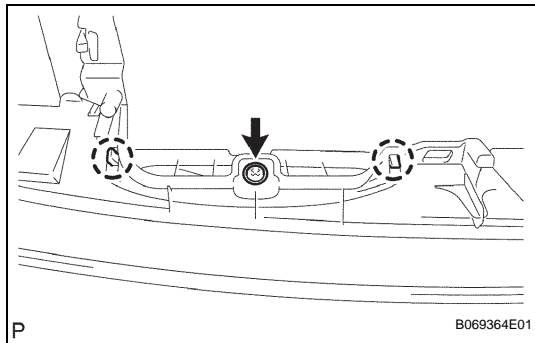
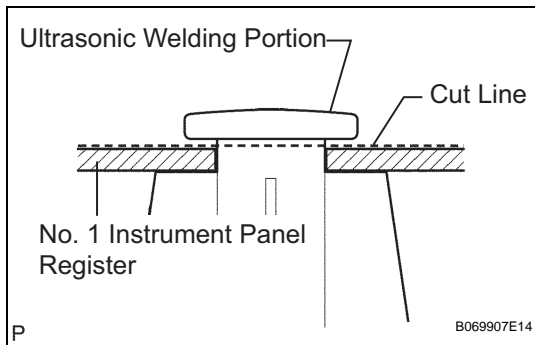

4. **REMOVE INSTRUMENT CLUSTER FINISH PANEL END**
  - (a) Remove the screw.
  - (b) Disengage the 2 claws and remove the instrument cluster finish panel end.
5. **REMOVE FRONT PASSENGER AIRBAG ASSEMBLY**  
(See page [RS-201](#))
6. **REMOVE NO. 1 INSTRUMENT PANEL CUSHION**
  - (a) Remove the No. 1 instrument panel cushion from the instrument panel sub-assembly.