

Front Wiper and Washer

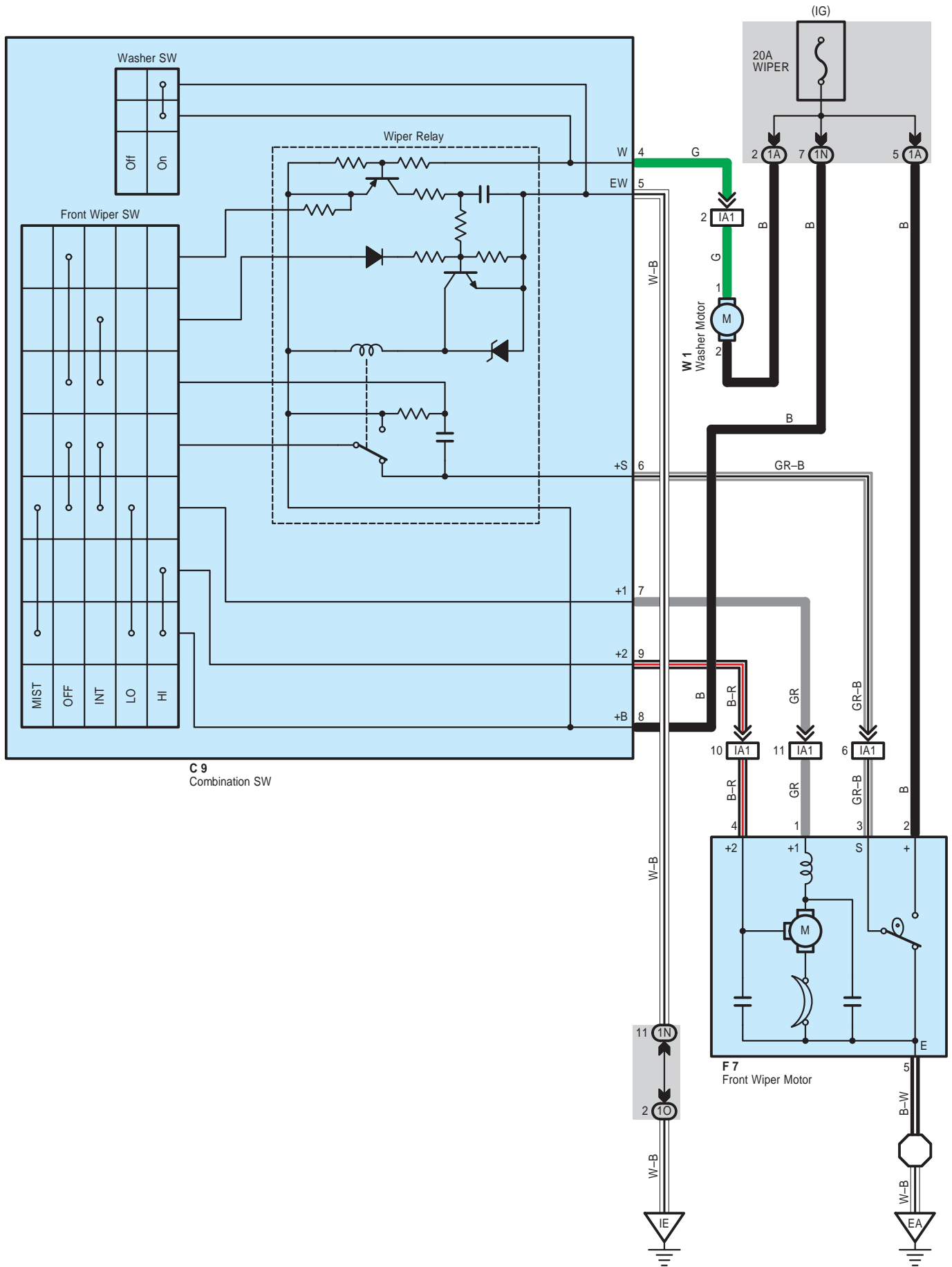

System Outline

With the ignition SW turned on, the current flows to TERMINAL 8 of the front wiper and washer SW, TERMINAL 2 of the washer motor and TERMINAL 2 of the front wiper motor through the WIPER fuse.

1. Low Speed Position

With the front wiper SW turned to LO position, the current flows from TERMINAL 8 of the front wiper and washer SW to TERMINAL 7 to TERMINAL 1 of the front wiper motor to TERMINAL 5 to GROUND and causes the front wiper motor to run at low speed.

2. High Speed Position

With the front wiper SW turned to HI position, the current flows from TERMINAL 8 of the front wiper and washer SW to TERMINAL 9 to TERMINAL 4 of the front wiper motor to TERMINAL 5 to GROUND and causes the front wiper motor to run at high speed.

3. INT Position

With the front wiper SW turned to INT position, the wiper relay operates and current flows from TERMINAL 8 of the front wiper and washer SW to TERMINAL 5 to GROUND. This activates the intermittent circuit and the current flows from TERMINAL 8 of the front wiper and washer SW to TERMINAL 7 to TERMINAL 1 of the front wiper motor to TERMINAL 5 to GROUND and the wiper operates. Intermittent operation is controlled by a condenser charge and discharge function in the relay.

4. Mist Position

With the front wiper SW turned to MIST position, the current flows from TERMINAL 8 of the front wiper and washer SW to TERMINAL 7 to TERMINAL 1 of the front wiper motor to TERMINAL 5 to GROUND and causes the front wiper motor to run at low speed.

5. Washer Interlocking Operation

With the washer SW pulled to ON position, the current flows from the WIPER fuse to TERMINAL 2 of the washer motor to TERMINAL 1 to TERMINAL 4 of the front wiper and washer SW to TERMINAL 5 to GROUND and causes the washer motor to run and the window washer to spray. Simultaneously, current flows from the WIPER fuse to TERMINAL 8 of the front wiper and washer SW to TERMINAL 7 to TERMINAL 1 of the front wiper motor to TERMINAL 5 to GROUND, causing the wiper to function.

○ : Parts Location

Code	See Page	Code	See Page	Code	See Page
C9	30	F7	28	W1	29

○ : Junction Block and Wire Harness Connector

Code	See Page	Junction Block and Wire Harness (Connector Location)
1A	24	Engine Room Main Wire and Instrument Panel J/B (Lower Finish Panel)
1N	25	Instrument Panel Wire and Instrument Panel J/B (Lower Finish Panel)
1O		

□ : Connector Joining Wire Harness and Wire Harness

Code	See Page	Joining Wire Harness and Wire Harness (Connector Location)
IA1	35	Engine Room Main Wire and Instrument Panel Wire (Behind the Reinforcement LH)

▽ : Ground Points

Code	See Page	Ground Points Location
EA	34	Front Right Fender Apron
IE	35	Left Kick Panel