

Door Lock Control

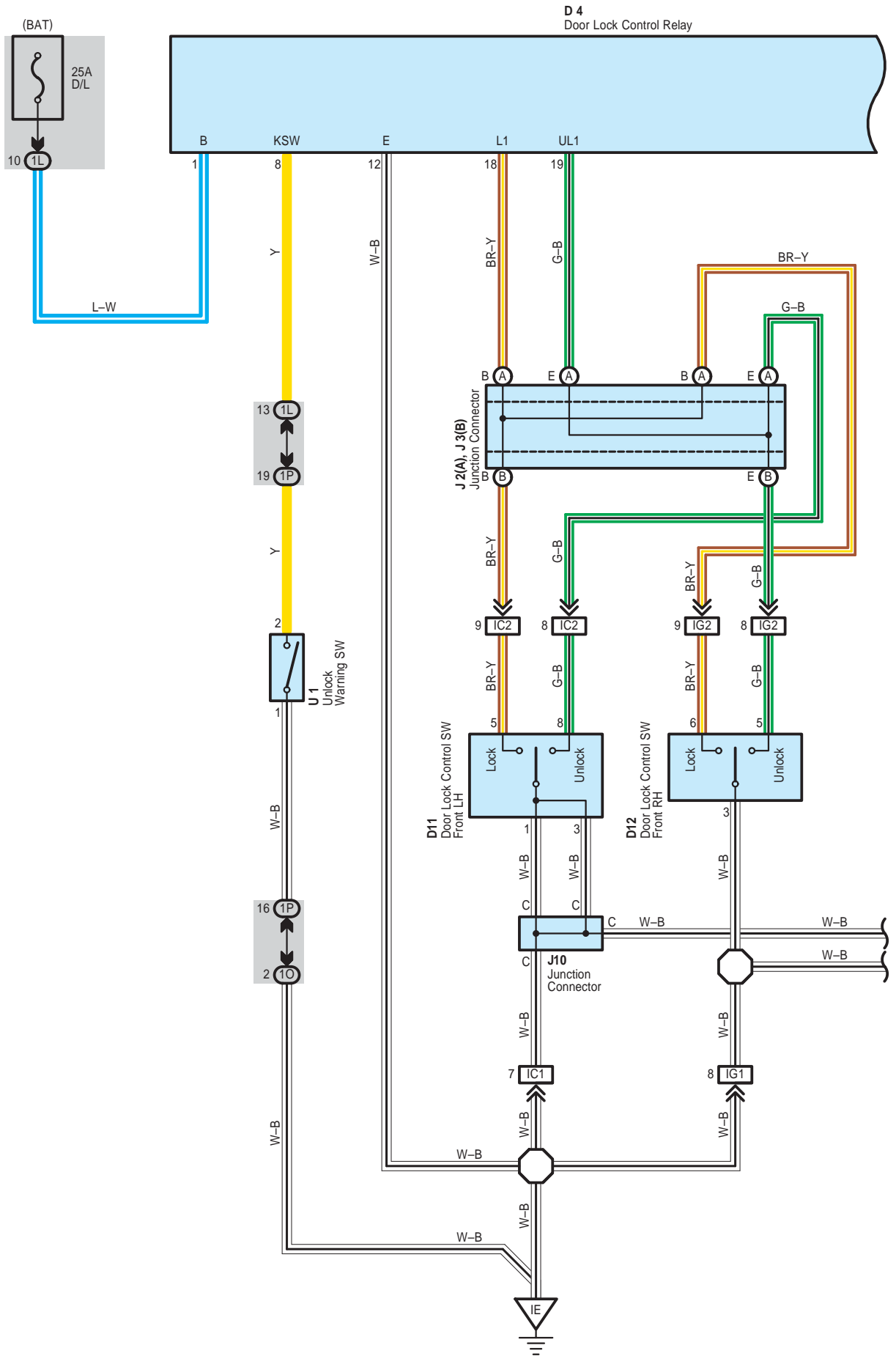

D 4
Door Lock Control Relay

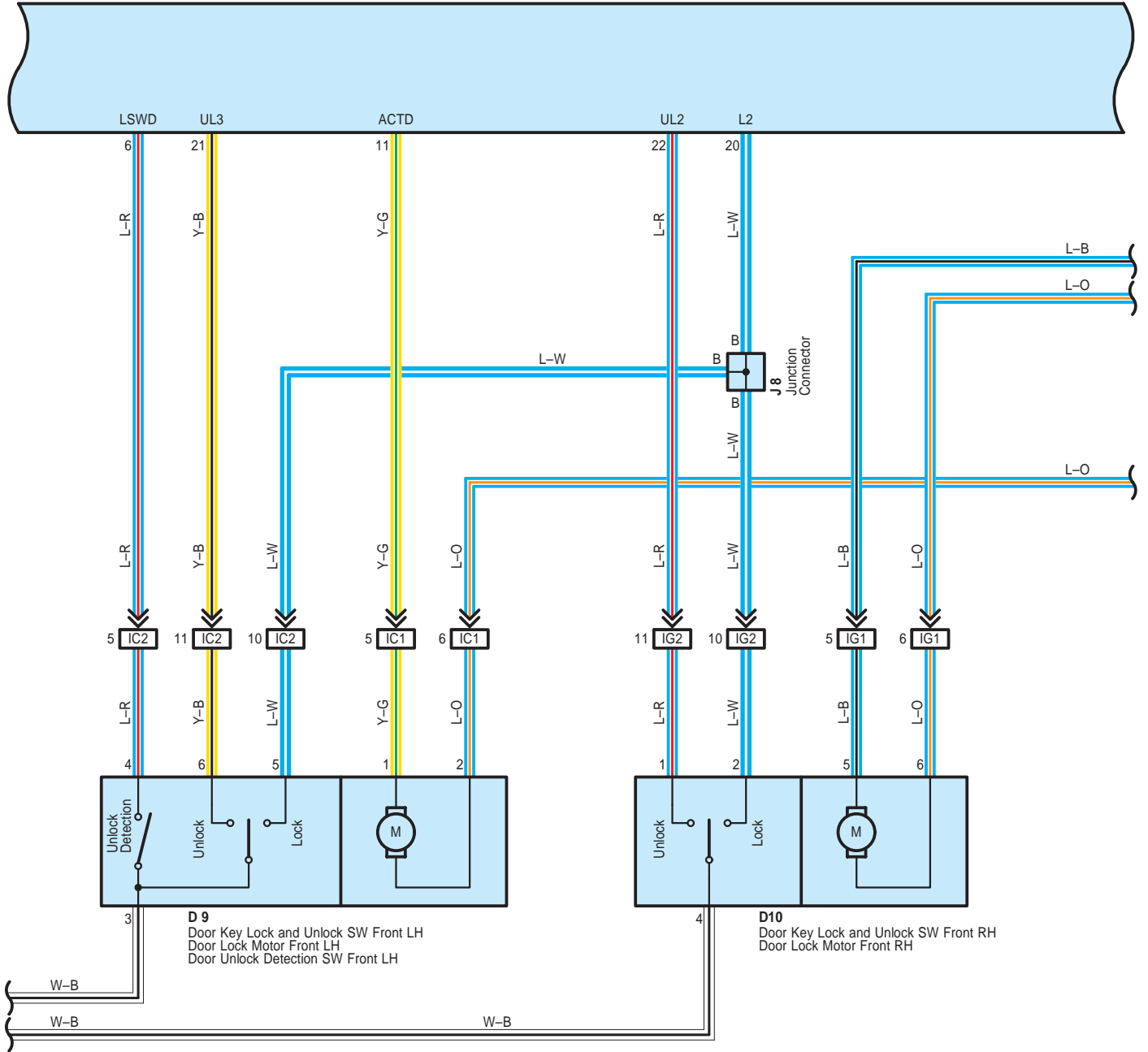

Door Lock Control

D 4
Door Lock Control Relay

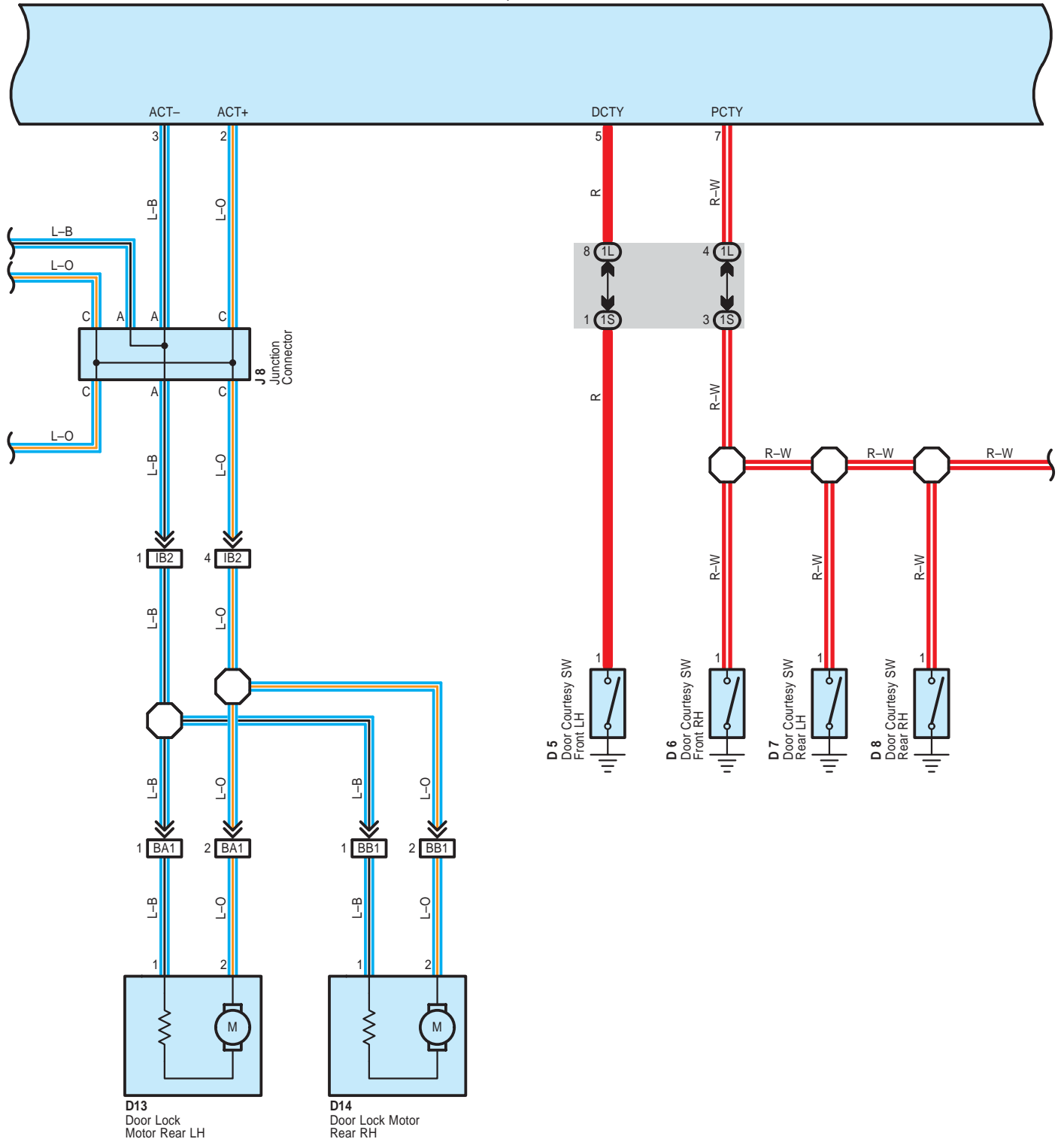

D 4
Door Lock Control Relay

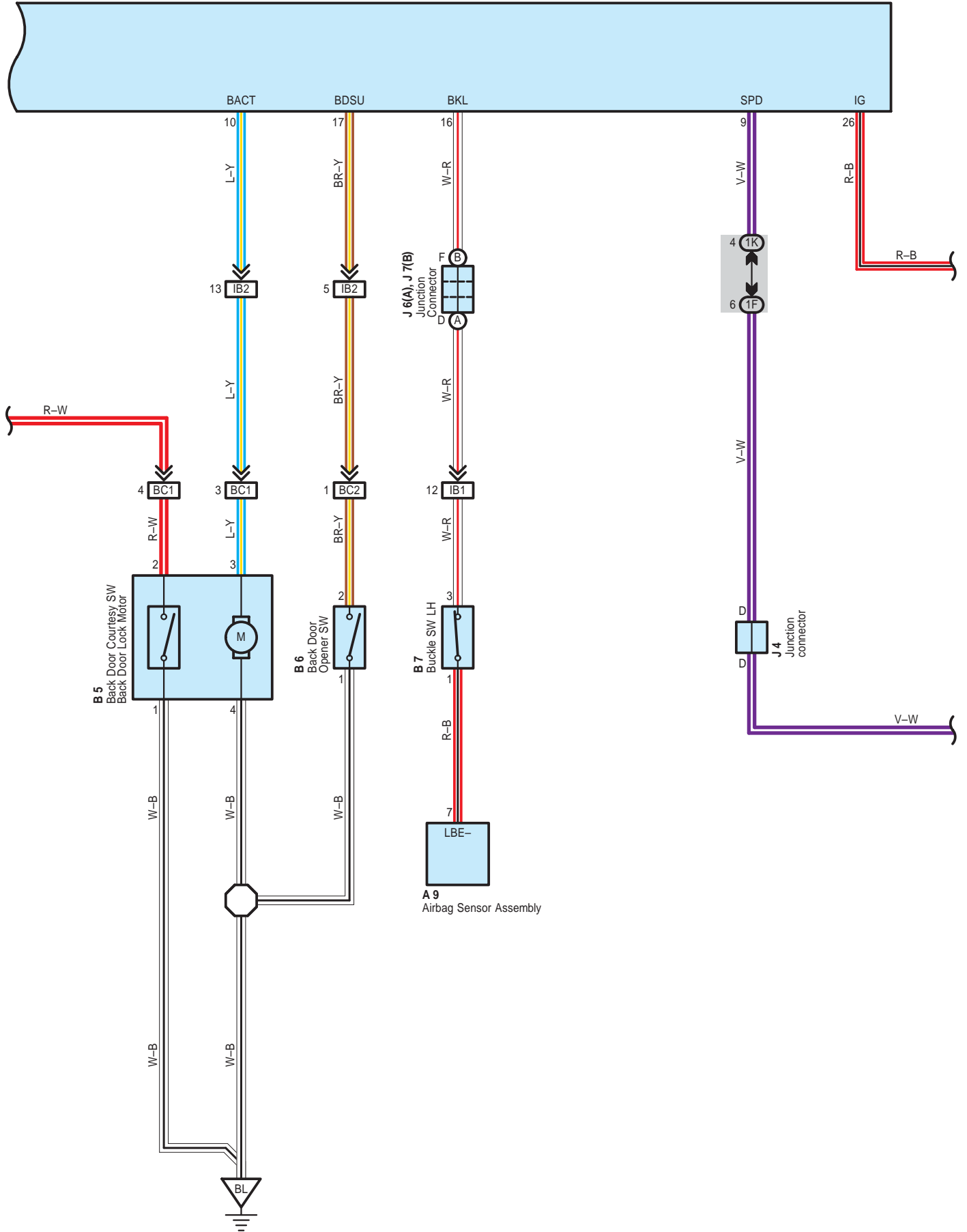

Door Lock Control

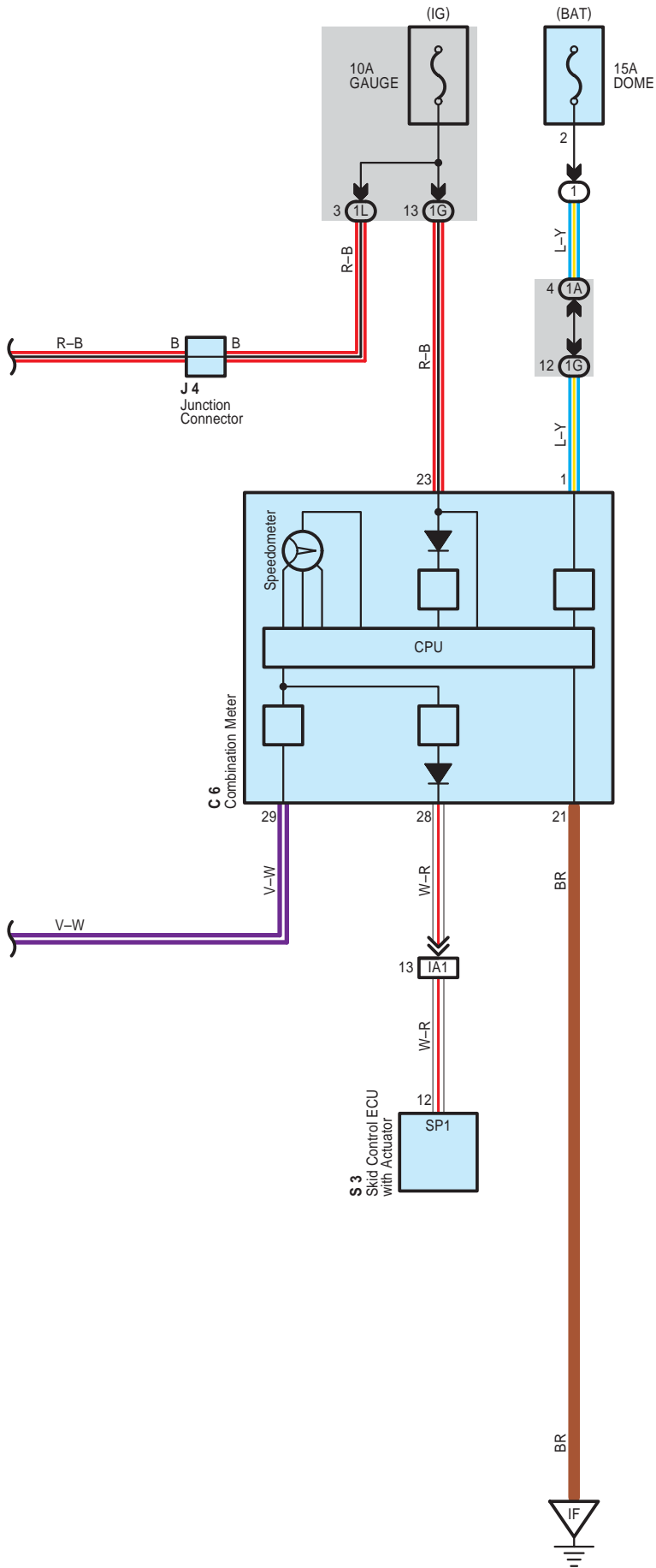

System Outline

The current always flows to TERMINAL 1 of the door lock control relay through the D/L fuse.

1. Manual Lock Operation

When the door lock control SW or door key lock and unlock SW are operated to LOCK position, a lock signal is input to TERMINAL 18 or 20 of the door lock control relay and causes the door lock control relay to function. The current flows from TERMINAL 1 of the door lock control relay to TERMINAL 2 to the door lock motors to TERMINALS 3 and 11 of the door lock control relay to TERMINAL 12 to GROUND and the door lock motors locks the door.

2. Manual Unlock Operation

When the door lock control SW or door key lock and unlock SW are operated to UNLOCK position, an unlock signal is input to TERMINAL 19, 21 or 22 of the door lock control relay and causes the door lock control relay to function. The current flows from TERMINAL 1 of the door lock control relay to TERMINALS 3 and 11 to the door lock motors to TERMINAL 2 of the door lock control relay to TERMINAL 12 to GROUND and the door lock motors unlocks the door.

3. Double Operation Unlock Operation

When the door key lock and unlock SW front LH is turned to the unlock side, only the driver's door is unlocked. By turning the door key lock and unlock SW front LH to the unlock side, a signal is input to TERMINAL 21 of the door lock control relay, and if the signal is input again within 3 seconds by turning the SW to the unlock side again, current flows from TERMINAL 11 of the door lock control relay to the door lock motors to TERMINAL 2 of the door lock control relay to TERMINAL 12 to GROUND, causing all the other doors are unlocked.

○ : Parts Location

Code	See Page	Code	See Page	Code	See Page
A9	30	D8	32	J4	31
B5	32	D9	32	J6	A 31
B6	32	D10	32	J7	B 31
B7	32	D11	32	J8	31
C6	30	D12	32	J10	32
D4	30	D13	32	S3	29
D5	32	D14	32	U1	31
D6	32	J2	A 31		
D7	32	J3	B 31		

○ : Relay Blocks

Code	See Page	Relay Blocks (Relay Block Location)
1	22	Engine Room R/B (Engine Compartment Left)

○ : Junction Block and Wire Harness Connector

Code	See Page	Junction Block and Wire Harness (Connector Location)
1A	24	Engine Room Main Wire and Instrument Panel J/B (Lower Finish Panel)
1F	25	Instrument Panel Wire and Instrument Panel J/B (Lower Finish Panel)
1G		
1K		
1L		
1O		
1P		
1S	24	Floor Wire and Instrument Panel J/B (Lower Finish Panel)

Door Lock Control

 : Connector Joining Wire Harness and Wire Harness

Code	See Page	Joining Wire Harness and Wire Harness (Connector Location)
IA1	35	Engine Room Main Wire and Instrument Panel Wire (Behind the Reinforcement LH)
IB1	35	Floor Wire and Instrument Panel Wire (Behind the Reinforcement LH)
IB2		
IC1	35	Front Door LH Wire and Instrument Panel Wire (Left Kick Panel)
IC2		
IG1	35	Front Door RH Wire and Instrument Panel Wire (Right Kick Panel)
IG2		
BA1	36	Rear Door No.1 LH Wire and Floor Wire (Center Pillar LH)
BB1	36	Rear Door No.1 RH Wire and Floor Wire (Center Pillar RH)
BC1	36	Back Door No.1 Wire and Floor Wire (Right Rear Side Quarter Pillar)
BC2		

 : Ground Points

Code	See Page	Ground Points Location
IE	35	Left Kick Panel
IF	35	Instrument Panel Brace LH
BL	36	Back Door Center

