

Wireless Door Lock Control

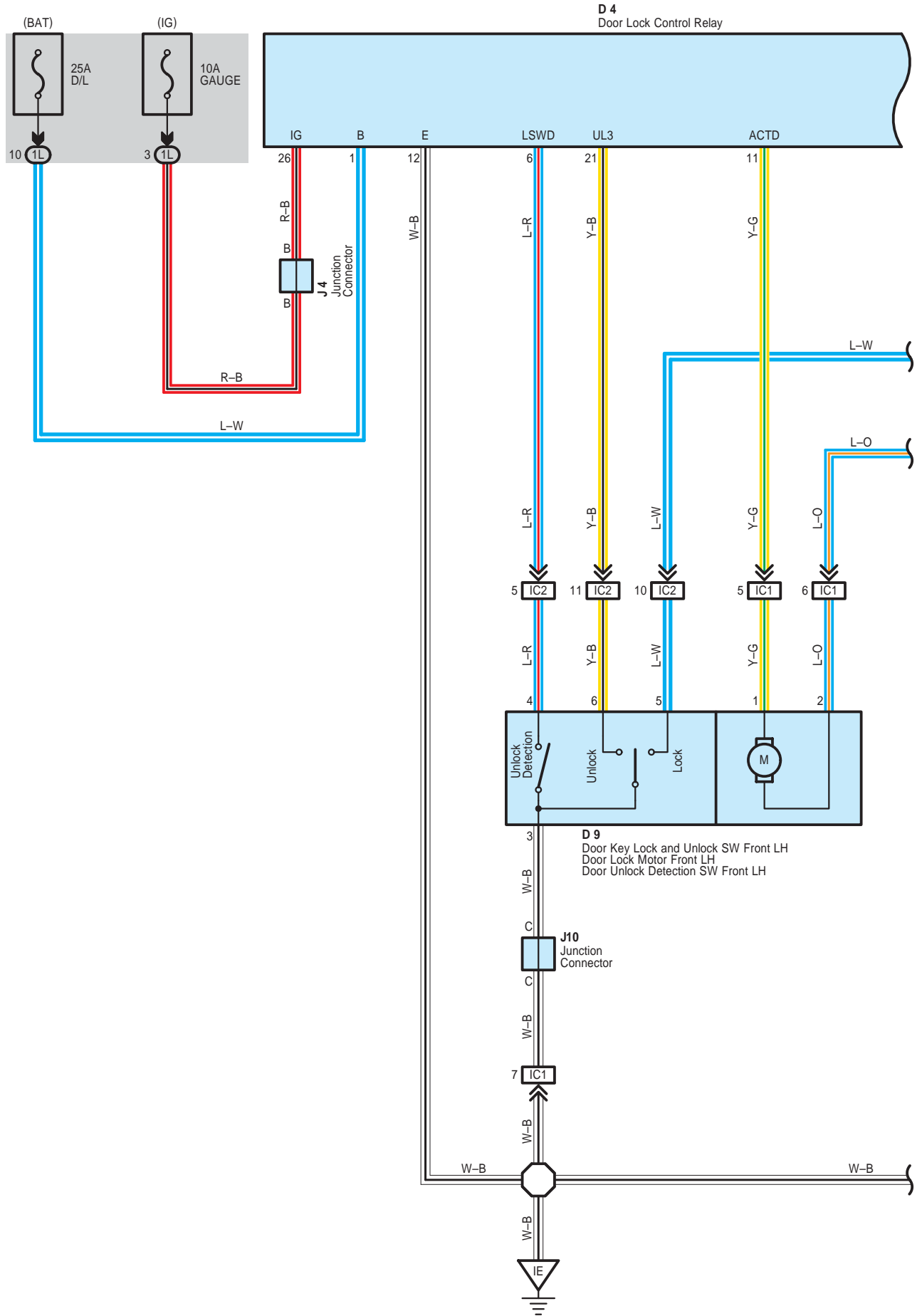

D 4
Door Lock Control Relay

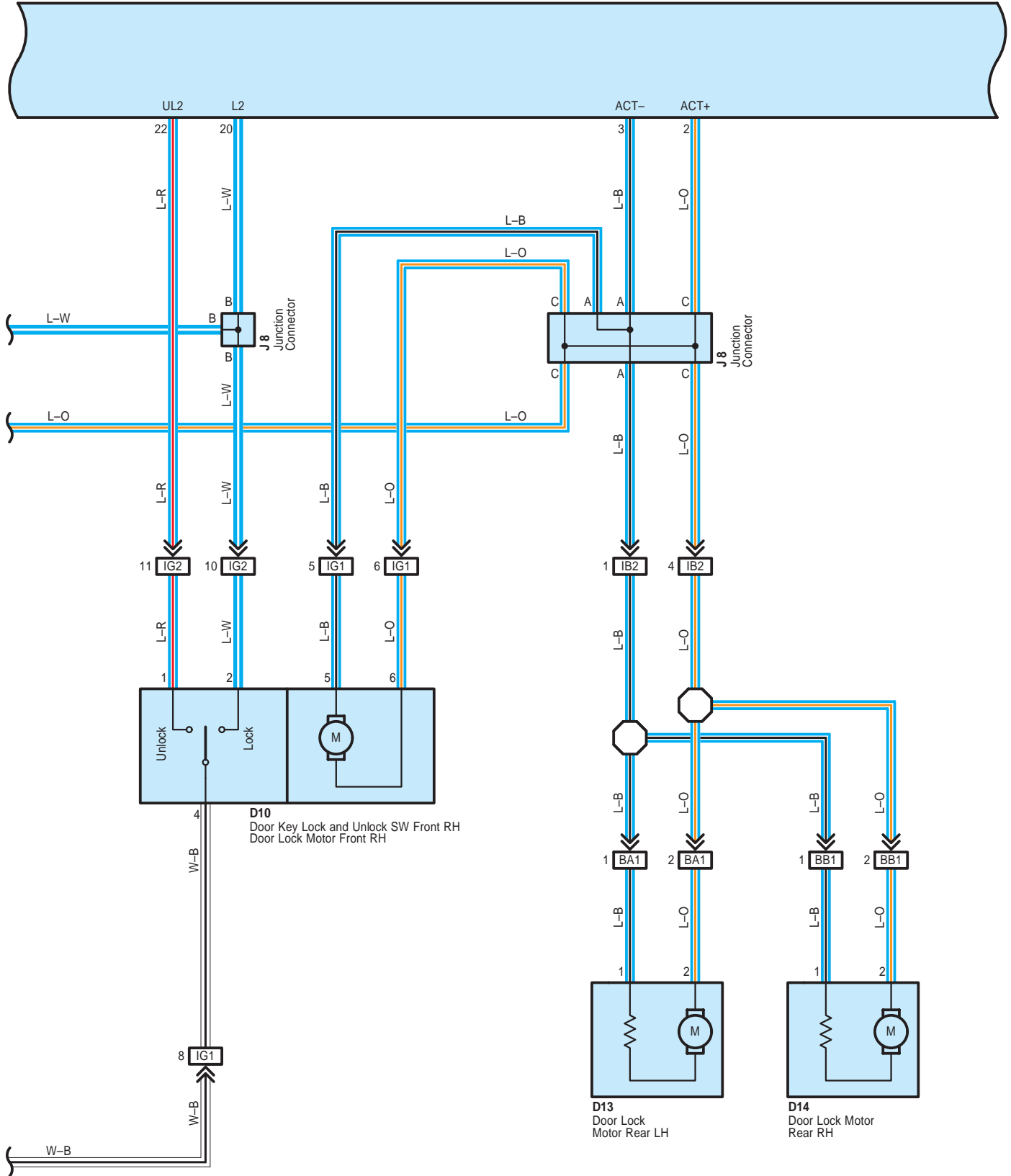

Wireless Door Lock Control

D 4
Door Lock Control Relay

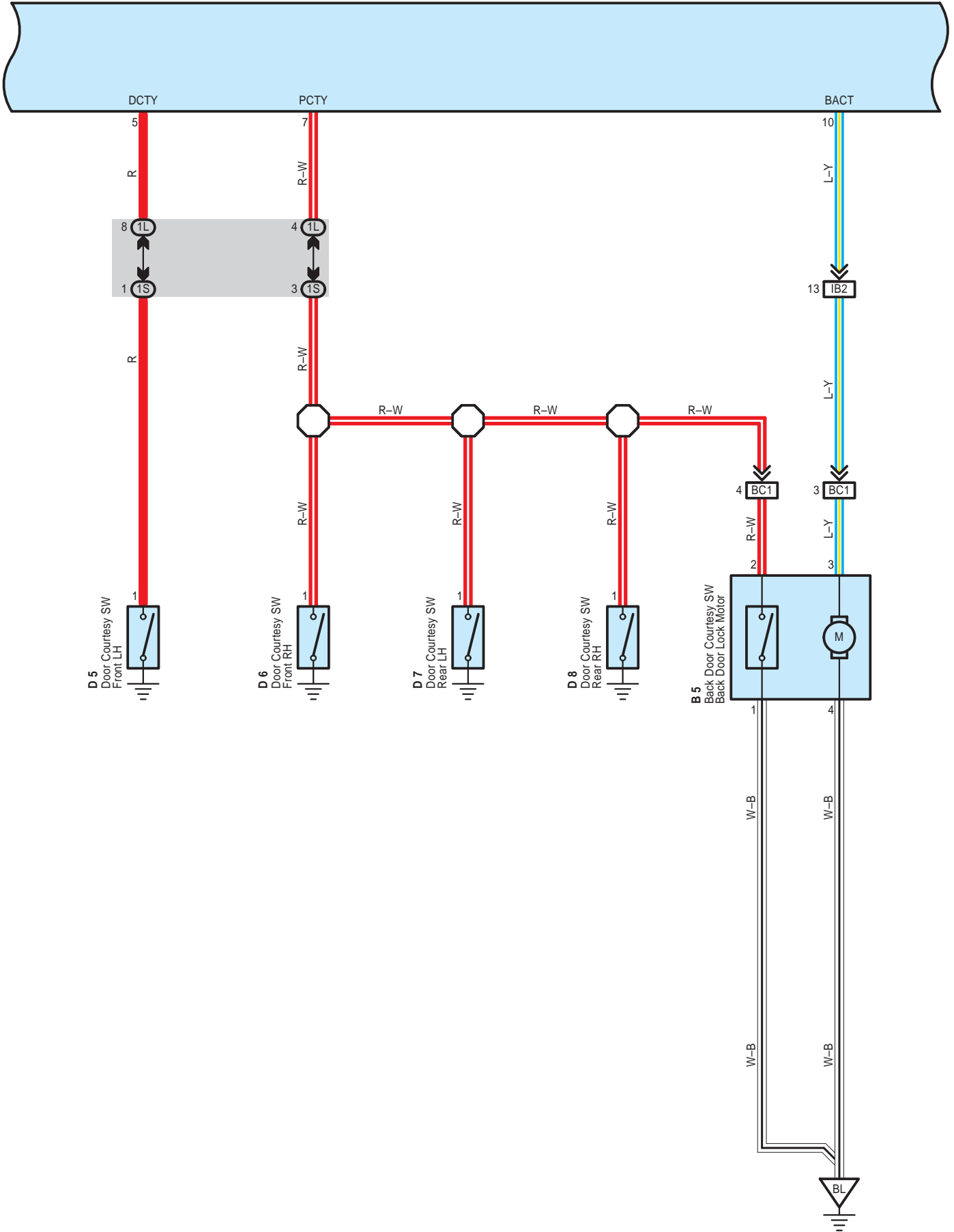

D 4
Door Lock Control Relay

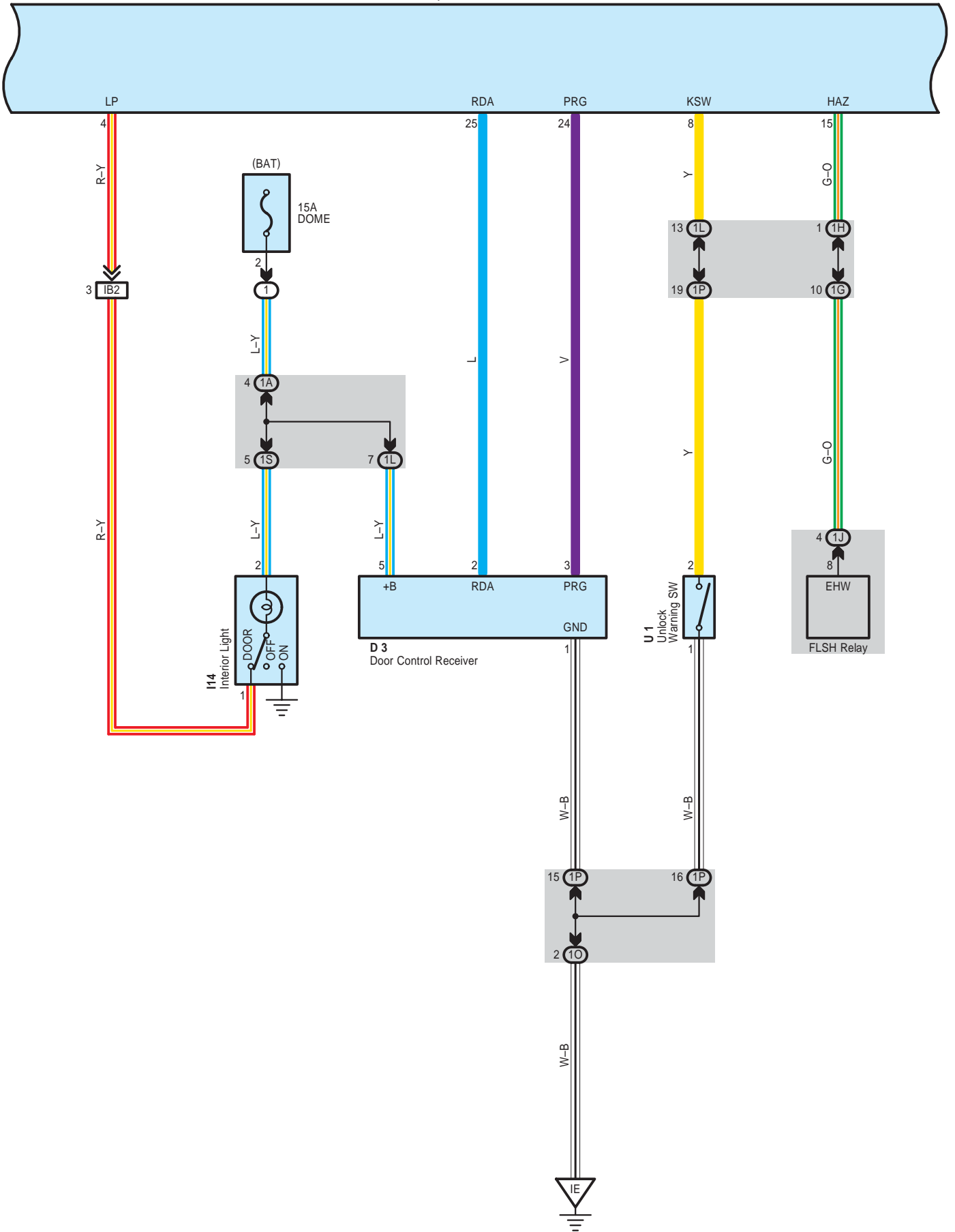

Wireless Door Lock Control

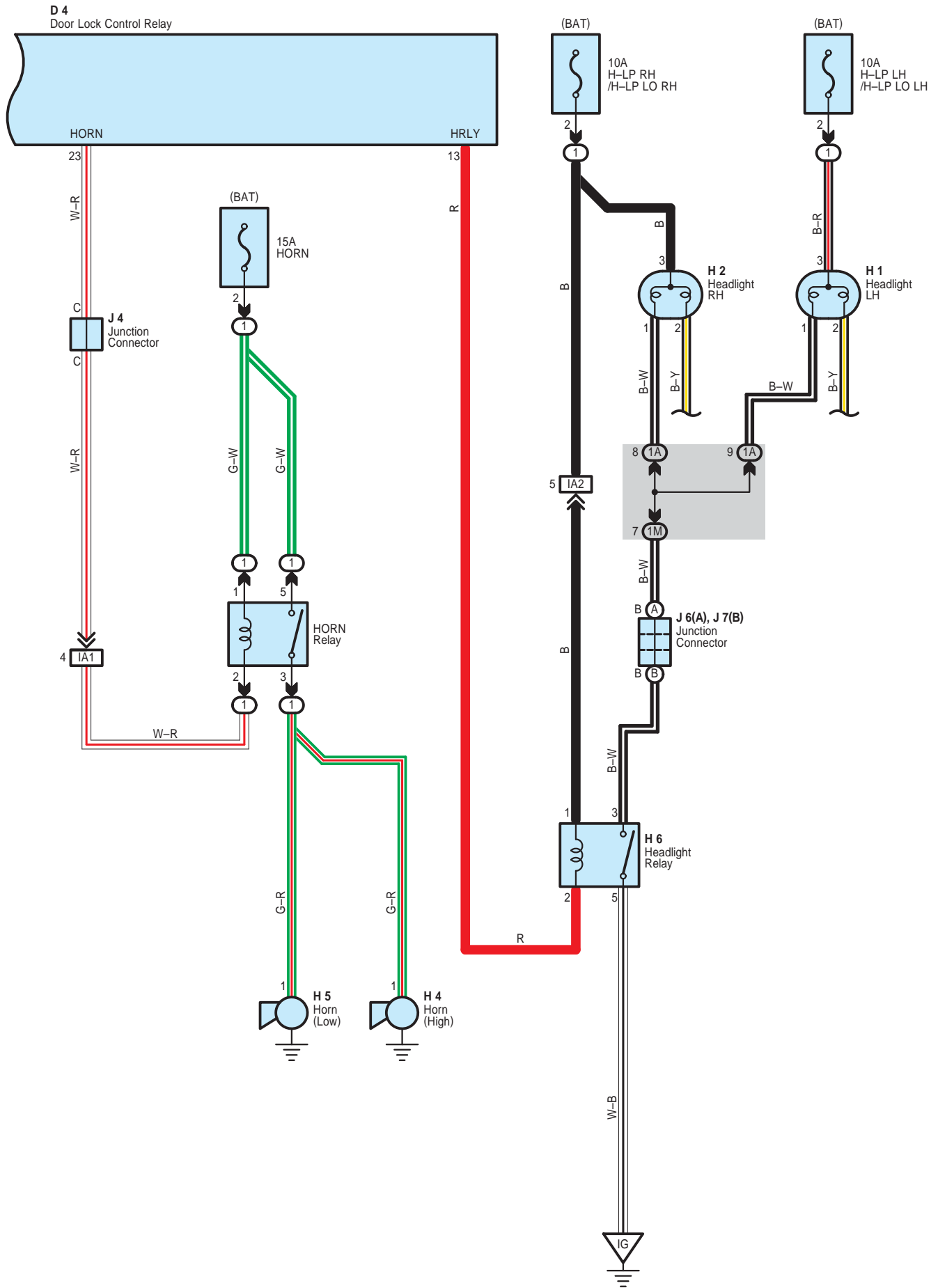

System Outline

Door lock control (Lock and unlock) and panic control (Theft alarm and flash) is performed by remote control, without the ignition SW at OFF, using low-power electrical waves emitted by a transmitter.

1. Wireless Door Lock or Unlock Normal Operation

With the ignition SW at OFF (Unlock warning SW off) and all the doors completely closed, when the lock or unlock button (Transmitter) is pushed, the wireless door lock control receiver receives the electrical waves from the transmitter, and sends a signal to the door lock control relay causing it to operate.

As a result, the door lock control relay judges whether the door is locked or unlocked based on the signal from the door lock motor and door unlock detection SW, and sends a signal to switch the condition from lock to unlock or vice versa, causing the door lock motor to operate.

2. Visual Confirmation of Lock or Unlock

If all doors indicate that they are locked after the lock command, parking lights and hazard lights will flash once. If any door indicates that it is open after the unlock command, parking lights and hazard lights will flash twice.

3. Wireless Door Unlock Operation

Pushing the unlock button (Transmitter) once, driver's door is unlocked. Furthermore, pushing the button again within 3 seconds, the other doors are unlocked.

4. Automatic Lock Operation

With the ignition key not inserted into the ignition key cylinder (Unlock warning SW off) and all the doors completely closed, after pushing the button (Transmitter) to unlock all the doors, if a door is not opened within 30 seconds, all the doors will be automatically relocked.

5. Wireless Control Stop Function

If a door is open (Door courtesy SW on), a signal is input from the door courtesy SW to the door lock control relay stopping wireless door lock or unlock.

If the ignition key is in the ignition key cylinder (Unlock warning SW on), the unlock warning SW inputs a signal to the door lock control relay stopping wireless door lock or unlock.

6. Repeat Function

In case an appropriate lock detection signal is not received after outputting a lock signal when pushing the lock button (Transmitter), 2 seconds later, the door lock control relay output the lock signal again.

7. Remote Panic Operation

Panic will function when doors are locked or unlocked, open or closed. When the panic button (Transmitter) is pushed once, theft alarm sounds and headlights and hazard lights flash. Then, the panic or the unlock button (Transmitter) is pushed once more, sounding and flashing will stop. Panic will not function when ignition SW at ON.

○ : Parts Location

Code	See Page	Code	See Page	Code	See Page
B5	32	D10	32	I14	32
D3	30	D13	32	J4	31
D4	30	D14	32	J6	A 31
D5	32	H1	28	J7	B 31
D6	32	H2	28	J8	31
D7	32	H4	28	J10	32
D8	32	H5	28	U1	31
D9	32	H6	30		

○ : Relay Blocks

Code	See Page	Relay Blocks (Relay Block Location)
1	22	Engine Room R/B (Engine Compartment Left)

Wireless Door Lock Control

: Junction Block and Wire Harness Connector

Code	See Page	Junction Block and Wire Harness (Connector Location)
1A	24	Engine Room Main Wire and Instrument Panel J/B (Lower Finish Panel)
1G	25	Instrument Panel Wire and Instrument Panel J/B (Lower Finish Panel)
1H		
1J		
1L		
1M		
1O		
1P		
1S	24	Floor Wire and Instrument Panel J/B (Lower Finish Panel)

: Connector Joining Wire Harness and Wire Harness

Code	See Page	Joining Wire Harness and Wire Harness (Connector Location)
IA1	35	Engine Room Main Wire and Instrument Panel Wire (Behind the Reinforcement LH)
IA2		
IB2	35	Floor Wire and Instrument Panel Wire (Behind the Reinforcement LH)
IC1	35	Front Door LH Wire and Instrument Panel Wire (Left Kick Panel)
IC2		
IG1	35	Front Door RH Wire and Instrument Panel Wire (Right Kick Panel)
IG2		
BA1	36	Rear Door No.1 LH Wire and Floor Wire (Center Pillar LH)
BB1	36	Rear Door No.1 RH Wire and Floor Wire (Center Pillar RH)
BC1	36	Back Door No.1 Wire and Floor Wire (Right Rear Side Quarter Pillar)

: Ground Points

Code	See Page	Ground Points Location
IE	35	Left Kick Panel
IG	35	Right Kick Panel
BL	36	Back Door Center

