

**Introduction** The following procedure is recommended for front license plate installation on Scion xB vehicles.

- Applicable Vehicles**
- 2005 – 2006 model year **Scion xB** vehicles.

- Installation Procedure**
1. Align the holes on the license plate to the dimples on the front bumper.
  2. Install two (2) self-tapping screws through the license plate and into the front bumper at the dimples.

**NOTE:**

- Do **NOT** drill holes into the bumper.
- Do **NOT** overtighten the screws.

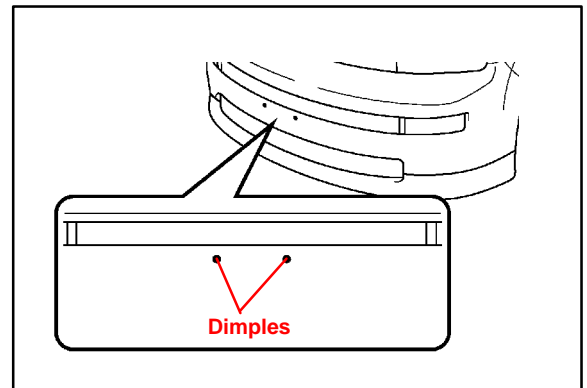

Use self-tapping screws of a non-corroding type with the following dimensions:

**Nominal Length: 18.0 mm (0.71 in.)**  
**Diameter: 6.0 mm (0.24 in.)**

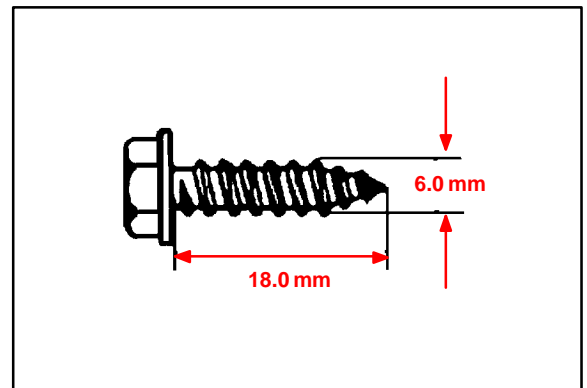

**Warranty Information**

OP CODE	DESCRIPTION	TIME	OFF	T1	T2
N/A	Not Applicable to Warranty	–	–	–	–

